

420-0024-01UK  
1<sup>st</sup> PRINTING

SEGA<sup>®</sup>

Sega Amusements International Limited  
42 Barwell Business Park, Leatherhead Road, Chessington, Surrey, KT9 2NY, United Kingdom.  
Telephone: +44 (0) 208 391 8090 Facsimile: +44 (0) 208 391 8089  
email: sales@segaarcade.com Web: http://www.segaarcade.com

© SEGA

Errors and Omissions Excepted (E&OE)

SONIC DASH EXTREME ARCADE

OWNERS MANUAL

420-0024-01UK

SEGA<sup>®</sup>

SONIC  
DASH<sup>™</sup>  
EXTREME

OWNER'S MANUAL



**IMPORTANT**

- Before using this product, read this manual carefully to understand the contents herein stated.
- After reading this manual, be sure to keep it near the product or in a convenient place for easy reference when necessary.

# BEFORE USING THE PRODUCT, BE SURE TO READ THE FOLLOWING:

## To maintain safety:

To ensure the safe operation of this product, be sure to read the following before usage. The following instructions are intended for the users, operators and the personnel in charge of the operation of the product. After carefully reading and sufficiently understanding the warning displays and cautions, handle the product appropriately. Be sure to keep this manual close to the product or in a convenient place for future reference.

Herein, explanations which require special attention are enclosed with dual lines. Depending on the potentially hazardous degrees, the terms of DANGER, WARNING, CAUTION, etc. are used. Be sure to understand the contents of the displays before reading the text.

 **DANGER** Indicates that mishandling the product by disregarding this pictograph will cause severe injury or death.

 **WARNING** Indicates that mishandling the product by disregarding this warning will cause a potentially hazardous situation which can result in death or serious injury.

 **CAUTION** Indicates that mishandling the product by disregarding this caution will cause a slight hazardous situation which can result in personal injury and/or material damage.

## For the safe usage of the product, the following pictographs are used:



Indicates "HANDLE WITH CARE." In order to protect the human body and equipment, this display is attached to places where the instruction manual should be referred to.



Indicates a "protective earth terminal." Before operating the equipment, be sure to connect it to the ground.  
(The step may be omitted for products in which a power cable with earth is used.)

- **Perform work in accordance with the instructions herein stated.**  
Instructions for work are explained by paying attention to the aspect of accident prevention. Failing to perform work as per the instructions can cause accidents. In the case where only those who have technical expertise should perform the work to avoid hazardous situation, the instructions herein state that the site maintenance personnel should perform such work.
- **Be sure to turn off the power before working on the machine.**  
To prevent an electric shock, be sure to turn off the power and unplug the power cable before carrying out any work that requires direct contact with the interior of the product. If the work is to be performed in the power-on status, the instruction manual herein always states to that effect.
- **Be sure to ground the earth terminal.**  
**(This is not required in the case where a power cable with earth is used.)**  
This product is equipped with the earth terminal. When installing the product, connect the earth terminal to the "accurately grounded indoor earth terminal" by using an earth wire. Unless the product is grounded appropriately, the user can be subject to an electric shock. After performing repair, etc. for the control equipment, ensure that the earth wire is firmly connected to the control equipment.
- **Ensure that the power supply used is equipped with an earth leakage breaker.**  
Using a power supply which is not equipped with the earth leakage breaker can cause a fire when earth leakage occurs.
- **Be sure to use fuses which meet the specified rating.**  
**(Only for the machines which use fuses.)**  
Using fuses exceeding the specified rating can cause a fire and an electric shock.

- **Specification changes (removal of equipment, conversion and addition) not designated by SEGA are not allowed.**

The parts of the product include warning labels for safety, covers for personal protection, etc. It is very hazardous to operate the product by removing parts and/or modifying the circuits. Should doors, lids and protective parts be damaged or lost, refrain from operating the product, and contact where the product was purchased from or the office herein stated.

SEGA shall not be held responsible for any accidents, compensation for damage to a third party, resulting from the specifications not designated by SEGA.

- **Ensure that the product meets the requirements of appropriate electrical specifications.**

Before installing the product, check for electrical specifications. SEGA products have a nameplate on which electrical specifications are described. Ensure that the product is compatible with the power supply voltage and frequency requirements of the location. Using any electrical specifications different from the designated specifications can cause a fire and an electric shock.

- **Install and operate the product in places where appropriate lighting is available, allowing warning labels to be clearly read.**

To ensure safety for the customers, labels and printed instructions describing potentially hazardous situations are applied to places where accidents can be caused. Ensure that where the product is operated has sufficient lighting allowing the warnings to be read. If any label is peeled off, apply it again immediately. Please place an order with where the product was purchased from or the office herein stated.

- **When handling the monitor, be very careful. (Applies only to products with monitors.)**

Some of the monitor parts are subject to high tension voltage. Even after turning off the power, some portions are still subject to high tension voltage sometimes. Monitor repair and replacement should be performed only by those technical personnel who have knowledge of electricity and technical expertise.

- **Be sure to adjust the monitor properly. (Applies only to products with monitors.)**

Do not operate the product leaving on-screen flickering or blurring as it is. Using the product with the monitor not properly adjusted may cause dizziness or a headache to an operator, a player, or the customers.

- **When transporting or reselling this product, be sure to attach this manual to the product.**

\* *In the case where commercially available monitors and printers are used in this product, only the contents relating to this product are explained herein. Some commercially available equipment has functions and reactions not stated in this manual. Read this manual together with the specific instruction manual of such equipment.*

\* *Descriptions herein contained may be subject to improvement changes without notice.*

\* *The contents described herein are fully prepared with due care. However, should any question arise or errors be found, please contact SEGA.*

## INSPECTIONS IMMEDIATELY AFTER TRANSPORTING THE PRODUCT TO THE LOCATION

Normally, at the time of shipment, SEGA products are in a status allowing for usage immediately after transporting to the location. Nevertheless, an irregular situation may occur during transportation. Before turning on the power, check the following points to ensure that the product has been transported in a satisfactory status.

- Are there any dented portions or defects (cuts, etc.) on the external surfaces of the cabinet?
- Are casters and adjusters damaged?
- Do the power supply voltage and frequency requirements meet with those of the location?
- Are all wiring connectors correctly and securely connected? Unless connected in the correct way, connector connections can not be made accurately. Do not insert connectors forcibly.
- Do power cables have cuts and dents?
- Are all accessories available?
- Can all doors and lids be opened with the accessory keys? Can doors and lids be firmly closed?

# INTRODUCTION

This manual is intended to provide detailed descriptions together with all necessary information covering the general operation of electronic assemblies, electro-mechanicals, servicing control, spare parts, etc. for the product, "SONIC DASH EXTREME" Arcade

This manual is intended for the owners, personnel managers in charge of operation of this product. Operate the product after carefully reading and sufficiently understanding the instructions.

In the unlikely event that the product does not function correctly, DO NOT allow anyone other than a technician to touch the internal system. Turn off the power to the machine, making sure to unplug the electrical cord from the outlet, and contact the office listed below or the point-of-purchase for this product.

Use of this product is unlikely to cause physical injuries or damage to property. However, points that require special attention are indicated by bold text, the word "IMPORTANT" and the symbol below.

## **IMPORTANT**

**Indicates important information that, if ignored, may result in the mishandling of the product and cause faulty operation or damage to the product.**

### **Sega Amusements International Limited.**

42 Barwell Business Park, Leatherhead Road, Chessington, Surrey, KT9 2NY. United Kingdom.

Telephone: +44 (0) 208 391 8090 Facsimile: +44 (0) 208 391 8089  
email: sales@segaarcade.com Web: <http://www.segaarcade.com>

## SPECIFICATIONS

Standard Cabinet	
Machine Dimensions:	1,09m (42.9in.) [Width] x 1.70m (49.2in.) [Depth]
Machine Height:	2.6m (102.3.) (Installed)
Machine Weight:	159kg Approx (Installed)
Power, maximum current:	AC115-240V 60~50Hz 1.1A (253W)



**Definition of 'Site Maintenance Personnel or Other Qualified Individuals'****STOP IMPORTANT**

**Procedures not described in this manual or marked as 'to be carried out by site maintenance personnel or other qualified professionals' should not be carried out by personnel without the necessary skill or technology. Work carried out by unqualified persons may cause serious accidents, including electrocution.**

Parts replacement, maintenance inspections and troubleshooting should be carried out by site maintenance personnel or other qualified professionals. This manual includes directions for potentially dangerous procedures which should only be carried out by professionals with the appropriate specialised knowledge.

The site maintenance personnel or other qualified professionals mentioned in this manual are defined as follows:

Site maintenance personnel:

Individuals with experience in maintaining amusement equipment, vending machines, etc., working under the supervision of the owner/operator of this product to maintain machines within amusement facilities or similar premises by carrying out everyday procedures such as assembly, maintenance inspections, and replacement of units/expendable parts.

Activities to be carried out by site maintenance personnel:

Amusement equipment/vending machine assembly, maintenance inspection and replacement of units/expendable parts.

Other qualified professionals:

Persons employed by amusement equipment manufacturers, or involved in design, production, testing or maintenance of amusement equipment. The individual should have either graduated from technical school or hold similar qualifications in electrical/electronics/mechanical engineering.

Activities to be carried out by other qualified professionals:

Amusement equipment/vending machine assembly, repair/adjustment of electrical/electronic/mechanical parts.

## Waste of Electrical and Electronic Equipment (WEEE) Statement.

The WEEE (Waste of Electrical and Electronic Equipment) directive places an obligation on all EU based manufacturers and importers of Electrical and Electronic Equipment to take back products at the end of their useful life. Sega Amusements Europe Ltd accepts its responsibility to finance the cost of treatment and recovery of redundant WEEE in the United Kingdom in accordance with the specified WEEE recycling requirements.

The symbol shown below will be on all products manufactured from 13th August 2005, which indicates this product must NOT be disposed of with other normal waste. Instead, it is the user's responsibility to dispose of their waste equipment by arranging to return it to a designated UK collection point for the correct recycling of waste electrical and electronic equipment.

For more information about where you can send your waste equipment for recycling contact your local authority office.

For non-UK users contact your local authority office for information on the recycling of Waste Electrical and Electronic Equipment.

## Battery Recycling Statement.

The EC Directive on Batteries and Accumulators (2006/66/EC) aims to minimise the impact of batteries on the environment and encourage the recovery of the materials they contain. To achieve increased collection and recycling of waste batteries, the Directive places 'producer responsibility' obligations on manufacturers and importers of portable, industrial and automotive batteries.

The symbol shown below will be on all equipment fitted with batteries from 26th September 2008 and indicates they must NOT be disposed of with other normal waste. Instead, it is the user's responsibility to dispose of used batteries by arranging to return them to a designated collection point for the correct recycling.

For more information about where you can send your waste batteries for recycling contact your local authority office.



REGISTERED IN ENGLAND REGISTERED NO. 1711515

REGISTERED OFFICE: BLOCK C 42 BARWELL BUSINESS PARK, CHESSINGTON, SURREY KT9 2NY

# MICROSOFT SOFTWARE LICENSE AGREEMENT

## WINDOWS EMBEDDED 8 STANDARD

Thank you for choosing a device preinstalled with Windows Embedded 8 Standard. This is a license agreement between you and SEGA. This agreement describes your rights to use the Windows Embedded 8 Standard software included on this device. The Windows Embedded 8 Standard software also includes any separate media on which you received the software. For your convenience, we've organized this agreement into two parts. The first part includes introductory terms phrased in a question and answer format; the Additional Terms follow and contain greater detail. You should review the entire agreement, including any linked terms, because all of the terms are important and together create this contract that applies to you. You can review linked terms by pasting the forward link into your browser window once the software is running. **The Additional Terms contain a binding arbitration clause and class action waiver. If you live in the United States, these affect your rights to resolve a dispute with SEGA, or with Microsoft, and you should read them carefully.**

**By accepting this agreement or using the software, you agree to all of these terms and consent to the transmission of certain information for Internet-based features of the software. If you do not accept and comply with these terms, you may not use the software or features.** Instead, you may contact SEGA to determine its return policy for a refund or credit under that policy.

**How can I use the software?** The software is licensed, not sold. Under this agreement, we grant you the right to install and run one copy only on the device with which you acquired the software (the licensed device), for use by one person at a time, but only if you comply with all the terms of this agreement. The software is not licensed to be used as server software or for commercial hosting – so, for example, you may not make the software available for simultaneous use by multiple users over a network. For more information on multiple user scenarios, see the Additional Terms.

**May I make a backup copy?** Yes, you may make a single copy of the software for backup purposes, and use that backup copy as described below.

**Can I transfer the software to another user?** You may transfer the software directly to another user, only with the licensed device. The transfer must include the software, proof of purchase, and, if provided with the device, an authentic Windows label such as the certificate of authenticity label, including the product key. You may not keep any copies of the software or any earlier version. Before any permitted transfer, the other party must agree that this agreement applies to the transfer and use of the software.

**Does the software collect my personal information?** If you connect your licensed device to the Internet, some features of the software may connect to Microsoft or service provider computer systems to send or receive information, including personal information. You may not always receive a separate notice when they connect. If you choose to use any of these features, you agree to send or receive this information when using that feature. Many of these features can be switched off or you can choose not to use them.

**How does Microsoft use your information?** Microsoft uses the information it collects through the software features to upgrade or fix the software and otherwise improve its products and services. In certain circumstances, Microsoft also shares it with others. For example, Microsoft shares error reports with relevant hardware and software vendors, so that the vendors can use the information to improve how their products run with Microsoft products. You agree that Microsoft may use and disclose the information as described in Microsoft's Privacy Statement at [go.microsoft.com/fwlink/?linkid=190175](http://go.microsoft.com/fwlink/?linkid=190175).

**What does this agreement apply to?** The Windows Embedded 8 Standard software on this licensed device includes software licensed from Microsoft Corporation or its affiliate. This agreement (including any printed-paper license terms that accompany the software) applies to the software, any separate media on which you received the software, and any Microsoft updates, supplements, and services for the software, unless other terms come with them.

**Are there things I'm not allowed to do with the software?** Yes. Because the software is licensed, not sold, SEGA and Microsoft reserve all rights (such as rights under intellectual property laws) not expressly granted in this agreement. In particular, this license does not give you any right to, and you may not: use features of the software separately; publish, copy (other than the permitted backup copy), rent, lease, or lend the software; transfer the software (except as permitted by this agreement); attempt to circumvent technical protection measures in the software; or reverse engineer, decompile, or disassemble the software, except if the laws where you live permit this even when this agreement does not. In that case, you may do only what your law allows. When using Internet-based features, you may not use those features in any way that could interfere with anyone else's use of them, or to try to gain access to any service, data, account, or network in an unauthorized manner.

### ADDITIONAL TERMS

#### 1. License Rights and Use Scenarios

- a. Device. In this agreement, "device" means a hardware system with internal storage capable of running the software. The software is licensed to run on up to two processors on the licensed device at any one time.
- b. Specific Use. SEGA designed the licensed device for a specific use. You may only use the software for that use.
- c. Other Software. You may use other programs with the software as long as the other programs
  - directly support the specific use for the licensed device, or
  - provide system utilities, resource management, or anti-virus or similar protection.
 Software that provides consumer or business tasks or processes may not run on the licensed device. This includes word processing, spreadsheet, database, scheduling and personal finance software. The licensed device may use terminal services protocols to access such software running on a server.
- d. Device connections. You may not use the software as server software. In other words, more than one device may not access, display, run, share or use the software at the same time. You may allow up to 20 other devices to access the software installed on the licensed device for the purpose of using file services, print services, Internet information services, and Internet connection sharing and telephony services on the licensed device. The 20 connection limit applies to devices that access the software indirectly through "multiplexing" or other software or hardware that pools connections. You may use unlimited inbound connections at any time via TCP/IP.
- e. Remote Access Technologies. The software contains Remote Desktop and Remote Assistance technologies that enable the software or applications installed on the licensed device to be accessed remotely from other devices.
  - Remote Desktop. The single primary user of the licensed device may access a session from any other device using Remote Desktop or similar technologies. A "session" means the experience of interacting with the software, directly or indirectly, through any combination of input, output and display peripherals. Other users, one at a time, may access the licensed software running on this host device, from any device using Remote Desktop, but only if the remote device is separately licensed to run Windows Embedded 8 Standard.
  - Remote Assistance. You may use Remote Assistance or similar technologies to share an active session without obtaining any additional licenses for the software. Remote Assistance allows one user to directly connect to another user's device, usually to correct problems.

#### 2. Binding Arbitration and Class Action Waiver

- a. Application. This Section 2 applies to any dispute EXCEPT IT DOES NOT INCLUDE A DISPUTE RELATING TO THE ENFORCEMENT OR VALIDITY OF YOUR, SEGA'S, OR EITHER OF OUR LICENSORS' INTELLECTUAL PROPERTY RIGHTS. Dispute means any dispute, action, or other controversy between you and SEGA, or you and Microsoft, concerning the software (including its price) or this agreement, whether in contract, warranty, tort, statute, regulation, ordinance, or any other legal or equitable basis. "Dispute" will be given the broadest possible meaning allowable under law.
- b. Notice of Dispute. In the event of a dispute, you or SEGA must give the other a Notice of Dispute, which is a written statement of the name, address, and contact information of the party giving it, the facts giving rise to the dispute, and the relief requested. Send it by U.S. Mail to SEGA, ATTN: LEGAL DEPARTMENT. SEGA will send any Notice of Dispute to your U.S. Mail address if available, or otherwise to your e-mail address. You and SEGA will attempt to resolve any dispute through informal negotiation within 60 days from the date the Notice of Dispute is sent. After 60 days, you or SEGA may commence arbitration.
- c. Small claims court. You may also litigate any dispute in small claims court in your county of residence or the SEGA's principal place of business, if the dispute meets all requirements to be heard in the small claims court. You may litigate in small claims court whether or not you negotiated informally first.
- d. Binding arbitration. If you and SEGA, or Microsoft, do not resolve any dispute by informal negotiation or in small claims court, any other effort to resolve the dispute will be conducted exclusively by binding arbitration. You are giving up the right to litigate (or participate in as a party or class member) all disputes in court before a judge or jury. Instead, all disputes will be resolved before a neutral arbitrator, whose decision will be final except for a limited right of appeal under the Federal Arbitration Act. Any court with jurisdiction over the parties may enforce the arbitrator's award.
- e. Class action waiver. Any proceedings to resolve or litigate any dispute in any forum will be conducted solely on an individual basis. Neither you, SEGA, nor Microsoft, will seek to have any dispute heard as a class action, as a private attorney general action, or in any other proceeding in which any party acts or proposes to act in a representative capacity. No arbitration or proceeding will be combined with another without the prior written consent of all parties to all affected arbitrations or proceedings.
- f. Arbitration procedure. Any arbitration will be conducted by the American Arbitration Association (the "AAA"), under its Commercial Arbitration Rules. If you are an individual and use the software for personal or household use, or if the value of the dispute is \$75,000 or less whether or not you are an individual or how you use the software, the AAA Supplementary Procedures for Consumer-Related Disputes will also apply. To commence arbitration, submit a Commercial Arbitration Rules Demand for Arbitration form to the AAA. You may request a telephonic or in-person hearing by following the AAA rules. In a dispute involving \$10,000 or less, any hearing will be telephonic unless the arbitrator finds good cause to hold an in-person hearing instead. For more information, see [adr.org](http://adr.org) or call 1-800-778-7879. You agree to commence arbitration only in your county of residence or in the SEGA's principal place of business. SEGA agrees to commence arbitration only in your county of residence. The arbitrator may award the same damages to you individually as a court could. The arbitrator may award declaratory or injunctive relief only to you individually, and only to the extent required to satisfy your individual claim.

- g. **Arbitration fees and incentives**
- i. **Disputes involving \$75,000 or less.** SEGA will promptly reimburse your filing fees and pay the AAA's and arbitrator's fees and expenses. If you reject the SEGA's last written settlement offer made before the arbitrator was appointed ("last written offer"), your dispute goes all the way to an arbitrator's decision (called an "award"), and the arbitrator awards you more than the last written offer, SEGA will give you three incentives: (1) pay the greater of the award or \$1,000; (2) pay twice your reasonable attorney's fees, if any; and (3) reimburse any expenses (including expert witness fees and costs) that your attorney reasonably accrues for investigating, preparing, and pursuing your claim in arbitration. The arbitrator will determine the amounts.
  - ii. **Disputes involving more than \$75,000.** The AAA rules will govern payment of filing fees and the AAA's and arbitrator's fees and expenses.
  - iii. **Disputes involving any amount.** In any arbitration you commence, SEGA will seek its AAA or arbitrator's fees and expenses, or your filing fees it reimbursed, only if the arbitrator finds the arbitration frivolous or brought for an improper purpose. In any arbitration SEGA commences, it will pay all filing, AAA, and arbitrator's fees and expenses. It will not seek its attorney's fees or expenses from you in any arbitration. Fees and expenses are not counted in determining how much a dispute involves.
- h. **Claims or disputes must be filed within one year.** To the extent permitted by law, any claim or dispute under this agreement to which Section 2 applies must be filed within one year in small claims court (Section 2.c) or in arbitration (Section 2.d). The one-year period begins when the claim or dispute first could be filed. If such a claim or dispute is not filed within one year, it is permanently barred.
- i. **Severability.** If the class action waiver in Section 2.e is found to be illegal or unenforceable as to all or some parts of a dispute, then Section 2 will not apply to those parts. Instead, those parts will be severed and proceed in a court of law, with the remaining parts proceeding in arbitration. If any other provision of Section 2 is found to be illegal or unenforceable, that provision will be severed with the remainder of Section 2 remaining in full force and effect.
- j. **Third-Party Beneficiary.** Microsoft Corporation is not a party to this agreement but is a third-party beneficiary of your and the SEGA's agreement to resolve disputes through informal negotiation and arbitration. If your dispute is with Microsoft, Microsoft agrees to do everything SEGA agrees to do in Section 2, and you agree to do everything regarding Microsoft that Section 2 requires you to do regarding SEGA. Mail a Notice of Dispute with Microsoft to Microsoft Corporation, ATTN: LCA ARBITRATION, One Microsoft Way, Redmond, WA 98052-6399. You may commence an arbitration or small claims court case against Microsoft in your county of residence or King County, Washington.

### 3. CHOICE OF LAW

The laws of the state or country where you live govern all claims and disputes under this agreement, including breach of contract claims and claims under state consumer protection laws, unfair competition laws, implied warranty laws, for unjust enrichment, and in tort. If you acquired the software in any other country, the laws of that country apply. This agreement describes certain legal rights. You may have other rights, including consumer rights, under the laws of your state or country. You may also have rights with respect to the party from whom you acquired the software. This agreement does not change those other rights if the laws of your state or country do not permit it to do so.

### 4. INTERNET-BASED FEATURES; PRIVACY

The following software features use Internet protocols, which send to Microsoft (or its suppliers or service providers) device information, such as your Internet protocol address, the type of operating system, browser and name and version of the software you are using, and the language code of the device where the software is installed. Microsoft uses this information to make the Internet-based features available to you, in accordance with the Windows 8 Privacy Statement, at [go.microsoft.com/fwlink/?LinkId=190175](http://go.microsoft.com/fwlink/?LinkId=190175). Some Internet-based features may be delivered at a later date via Microsoft's Windows Update service—if, for example, you acquire an application that relies on one of those services. SEGA may have elected to turn on one or more of the following features in the licensed device.

- a. **Windows Update.** If you use the Windows Update service in the software, updates or downloads to the Windows Update service will be required for proper functioning of the service, from time to time, and will be downloaded and installed without further notice to you.
- b. **Windows Digital Rights Management technology.** Some content owners use Windows digital rights management technology (WDRM) to protect their copyrights and other intellectual property, including by disabling the software's ability to play protected content if WDRM fails. You agree that Microsoft may include a revocation list with the licenses.
- c. **Windows Media Player.** When you use Windows Media Player, it checks with Microsoft for compatible online music services in your region and new versions of the player. You may only use Windows Media Player as described at [go.microsoft.com/fwlink/?LinkId=104605](http://go.microsoft.com/fwlink/?LinkId=104605).
- d. **Windows Defender.** If turned on, Windows Defender will search your licensed device for many types of malicious software, including viruses, worms, bots, rootkits, "spyware", "adware" and other potentially unwanted software. If it finds potentially unwanted software, the software will ask you if you want to ignore, disable (quarantine) or remove it. If you choose the "recommended" security settings when you first start using the software, such malware and other potentially unwanted software rated "high" or "severe" will automatically be removed. This removal may result in other software on your licensed device ceasing to work or your breach in a license to use that software. It is possible that software that is not unwanted may be removed or disabled. If you use Windows Defender and Windows Update, Windows Defender is regularly updated through Windows Update.
- e. **Malicious software removal.** If you use Windows Update, at least once each month the software will scan for and remove from your licensed device the malware listed at [go.microsoft.com/fwlink/?LinkId=241725](http://go.microsoft.com/fwlink/?LinkId=241725). After the scan completes, a report will be sent to Microsoft with specific information about malware detected, errors, and other information about your device. This information is used to improve the software and other Microsoft products. You may disable the software's reporting functionality by following the instructions found at [go.microsoft.com/fwlink/?LinkId=241725](http://go.microsoft.com/fwlink/?LinkId=241725).
- f. **SmartScreen Filter.** If enabled, the SmartScreen Filter will check the addresses of webpages and downloads you attempt to view against a frequently updated list of webpages and downloads that have been reported to Microsoft as unsafe or suspicious. SmartScreen will also check downloaded programs that you attempt to run against a list of commonly downloaded or run programs to help you make more informed trust decisions. More information can be found by visiting the Internet Explorer Privacy Statement [go.microsoft.com/fwlink/?LinkId=239590](http://go.microsoft.com/fwlink/?LinkId=239590). By enabling SmartScreen in either Windows or Internet Explorer, you consent to this feature, and you agree to use the SmartScreen Filter only in conjunction with Windows or Internet Explorer. You may not, either manually or by enabling or authorizing any software or service, copy, display, distribute, collect or store any data provided by the SmartScreen Filter.
- g. **IPv6 Network Address Translation (NAT) Traversal service (Teredo).** Each time you start your licensed device, Teredo will attempt to locate a public Internet Protocol version 6 (IPv6) service on the Internet. This occurs automatically when your licensed device is connected to a public or private network, but does not occur on managed networks such as enterprise domains. If you use a program that requires Teredo to use IPv6 connectivity, or if you configure your firewall to always enable IPv6 connectivity, then Teredo will periodically contact the Microsoft Teredo service over the Internet. The only information sent to Microsoft is standard computer information and the name of the service requested (for example [teredo.ipv6.microsoft.com](http://teredo.ipv6.microsoft.com)). The information sent from your licensed device by Teredo is used to determine if your licensed device is connected to the Internet and if it can locate a public IPv6 service. Once the service is located, information is sent to maintain a connection with the IPv6 service.
- h. **Plug and Play and Plug and Play Extensions.** Your licensed device may not have the drivers needed to communicate with hardware that you connect to your licensed device. If so, the update feature of the software can obtain and install the correct driver on your licensed device. An administrator can disable this update feature.
- i. **Digital certificates.** The software uses digital certificates to confirm the identity of Internet users sending X.509 standard encrypted information, to digitally sign files and macros, and to verify the integrity and origin of file contents. The software may retrieve and update certificates, certificate revocation lists, and the list of trusted certification authorities, over the Internet.
- j. **Network awareness.** This feature determines whether a system is connected to a network by either passive monitoring of network traffic or active DNS or HTTP queries. The query transfers only standard TCP/IP or DNS information for routing purposes. You can switch off the active query feature through a registry setting.
- k. **Accelerators.** When you click on or move your mouse over an Accelerator in Internet Explorer, any of the following may be sent to the applicable service provider (which may not be Microsoft): the title and full web address or URL of the current webpage, standard computer information, and any content you have selected. For more information, see [go.microsoft.com/fwlink/?LinkId=239590](http://go.microsoft.com/fwlink/?LinkId=239590).
- l. **Search provider update.** The software will download an update to the data on your device about search providers. This update upgrades your providers with the latest features, such as new icons or search suggestions. This is a one-time update, but the software will try to perform the update several times if it does not successfully download the update. For more information, see [go.microsoft.com/fwlink/?LinkId=239590](http://go.microsoft.com/fwlink/?LinkId=239590).
- m. **Cookies.** If you choose to use online features in the software, such as online Help and Support, cookies may be set. To learn how to block, control and delete cookies, please read the cookies section of the privacy statement at [go.microsoft.com/fwlink/?linkId=74170](http://go.microsoft.com/fwlink/?linkId=74170).
- n. **Customer Experience Improvement Program (CEIP).** This software uses CEIP. CEIP automatically sends Microsoft information about your hardware and how you use this software. We do not use this information to identify or contact you. CEIP will also periodically download a small file to your computer. This file helps us collect information about problems that you have while using the software. When available, new help information about the errors might also be automatically downloaded. To learn more about CEIP, see <http://go.microsoft.com/fwlink/?LinkId=52097>.
- o. **Automatic Updates.** Software with Click-to-Run technology may check with Microsoft now and then for updates and supplements. If the software finds updates and supplements, it might download and install them on your licensed device.
- p. **Auto Root Update.** The Auto Root Update feature updates the list of trusted certificate authorities. You can switch off the Auto Root Update feature.
- q. **Microsoft Error Reporting Service.** This feature helps Microsoft and Windows partners diagnose problems in the software and provide solutions. Not all problems will have a solution but when a solution is available, it will be offered as a step to solve a problem you have reported or as an update to install. As part of setup and installation, the Microsoft Error Reporting Service sends to Microsoft information about setup and installation failures in order to attempt to diagnose the problem. To help prevent problems and make the software more reliable, some solutions are also included in service packs and future versions of the software.
- r. **Silverlight and Silverlight Software Development Kit.** Silverlight contains an Automatic Update feature that is on by default. You may turn off this feature while Silverlight is running ("opt out"). Unless you expressly opt out of this feature, this feature will

- connect to Microsoft or service provider computer systems over the Internet,
- use Internet protocols to send to the appropriate systems standard computer information, such as
- your computer's Internet protocol address,
- the type of operating system, browser and name and version of Silverlight you are using, and
- the language code of the device where you installed Silverlight, and
- automatically download and install, or prompt you to download and/or install, current updates to Silverlight.

In some cases, you will not receive a separate notice before this feature takes effect. By installing the software, you consent to the transmission of standard computer information and the automatic downloading and installation of updates.

- s. Microsoft Digital Rights Management. If you use Silverlight to access content that has been protected with Microsoft Digital Rights Management (DRM), in order to let you play the content, the software may automatically
- request media usage rights from a rights server on the Internet and
  - download and install available DRM Updates.

For more information about this feature, including instructions for turning the Automatic Updates off, go to [go.microsoft.com/fwlink/?LinkId=147032](http://go.microsoft.com/fwlink/?LinkId=147032).

- t. Windows Rights Management Services. The software contains a feature that allows you to create content that cannot be printed, copied or sent to others without your permission. You must connect to Microsoft to use this feature for the first time. Once a year, you must re-connect to Microsoft to update it. You may choose not to use this feature.
- u. Windows Time Service. This service synchronizes with [time.windows.com](http://time.windows.com) once a week to provide your licensed device with the correct time. You can turn this feature off or choose your preferred time source within the Date and Time Control Panel applet. The connection uses standard NTP protocol.
- v. Windows (or Microsoft) Update Feature. You may connect new hardware to the licensed device. Your licensed device may not have the drivers needed to communicate with that hardware. If so, the update feature of the software can obtain the correct driver from Microsoft and install it on your licensed device. You can switch off this update feature.

## 5. PROOF OF LICENSE

The elements of a valid license include a genuine product key, successful activation of the software, an authentic Windows label such as a Certificate of Authenticity (COA), and proof of purchase from a supplier of genuine Microsoft software. A valid license may also include a Windows activation file installed on the licensed device by SEGA. If there is a COA or other Windows label, it must be affixed to the licensed device or appear on the SEGA's software packaging or peripherals when purchased. If you receive an authenticity label separate from your licensed device, it does not establish proof of license. For further information about Microsoft genuine software, see [howtotell.com](http://howtotell.com).

## 6. UPDATES AND UPGRADES

You may only obtain updates or upgrades for the software from Microsoft or authorized sources. You may not be able to obtain certain updates or upgrades from SEGA, or Microsoft, if your copy of the software is improperly licensed. Certain upgrades, support, and other services may be offered only to users of genuine Microsoft software. For more information about Genuine Windows, see [go.microsoft.com/fwlink/?LinkId=104612](http://go.microsoft.com/fwlink/?LinkId=104612).

To use upgrade software, you must first be licensed for the software that is eligible for the upgrade. Upon upgrade, this agreement takes the place of the agreement for the software you upgraded from. After you upgrade, you may no longer use the software you upgraded from.

## 7. FONTS, ICONS, IMAGES, AND SOUNDS

- a. Font components. While the software is running, you may use its fonts to display and print content. You may temporarily download the fonts to a printer or other output device to print content, and you may embed fonts in content only as permitted by the embedding restrictions in the fonts.
- b. Icons, images, and sounds. While the software is running, you may access and use its icons, images, sounds, and media only from the licensed device. You may not share the sample images, sounds and media provided with the software or use them for any other purpose.

## 8. .NET FRAMEWORK

The software includes one or more components of the .NET Framework, which you may use only as described at [go.microsoft.com/fwlink/?LinkId=66406](http://go.microsoft.com/fwlink/?LinkId=66406) if you use the .NET Framework components to conduct internal benchmark testing.

## 9. VHD BOOT. Additional copies of the software created using the software's Virtual Hard Disk functionality ("VHD

Image") may be pre-installed on the physical hard disk of the licensed device. These VHD Images may only be used for maintaining or updating the software installed on the physical hard disk or drive. If the VHD Image is the only software on your device, it may be used as the primary operating system but all other copies of the VHD Image may only be used for maintenance and updating.

**10. NOT FAULT TOLERANT.** The software is not fault tolerant. SEGA installed the software on the licensed device and is responsible for how it operates on the device.

**11. RESTRICTED USE.** The Microsoft software was not designed for systems that require fault-tolerant performance. You may not use the Microsoft software in any device or system in which a failure or fault of any kind of the software could reasonably be seen to lead to death or serious injury of any person, or to severe physical or environmental damage.

**12. EXPORT RESTRICTIONS.** You must also comply with all domestic and international export laws and regulations that apply to the software, which include restrictions on destinations, end users, and end use. For further information on geographic and export restrictions, visit [go.microsoft.com/fwlink/?LinkId=141397](http://go.microsoft.com/fwlink/?LinkId=141397) and [microsoft.com/exporting](http://microsoft.com/exporting).

**13. NO WARRANTIES FOR THE SOFTWARE.** The software is provided "as is". You bear all risks of using it. Microsoft gives no express warranties, guarantees or conditions. Any warranties you receive regarding the licensed device or the software do not originate from, and are not binding on, Microsoft or its affiliates. When allowed by your local laws, SEGA and Microsoft exclude implied warranties of merchantability, fitness for a particular purpose and non-infringement.

**14. LIABILITY LIMITATIONS.** You can recover from Microsoft and its affiliates only direct damages up to two hundred fifty U.S. Dollars (U.S. \$250.00), or equivalent in local currency. You cannot recover any other damages, including consequential, lost profits, special, indirect or incidental damages.

This limitation applies to:

- anything related to the software, services, content (including code) on third party internet sites, or third party programs, and
- claims for breach of contract, breach of warranty, guarantee or condition, strict liability, negligence, or other tort to the extent permitted by applicable law.

It also applies even if Microsoft should have been aware of the possibility of the damages. The above limitation may not apply to you because your country may not allow the exclusion or limitation of incidental, consequential or other damages.

## 15. REFUND PROCEDURES

If you are seeking a refund, contact SEGA to determine its return policy for a refund or credit. You must comply with that policy, which might require you to return the software with the entire licensed device on which the software is installed for a refund.

## 16. ENTIRE AGREEMENT

This agreement (together with printed-paper license terms or other terms accompanying any software supplements, updates, and services that are provided by SEGA, or Microsoft, and that you use), and the terms contained in web links listed in this agreement, are the entire agreement for the software and any such supplements, updates, and services (unless SEGA, or Microsoft, provides other terms with such supplements, updates, or services).

**17. FOR AUSTRALIA ONLY.** Our goods come with guarantees that cannot be excluded under the Australian Consumer Law. You are entitled to a replacement or refund for a major failure and compensation for any other reasonably foreseeable loss or damage. You are also entitled to have the goods repaired or replaced if the goods fail to be of acceptable quality and the failure does not amount to a major failure. Goods presented for repair may be replaced by refurbished goods of the same type rather than being replaced. Refurbished parts may be used to repair the goods.

For further information regarding this warranty and to claim expenses in relation to the warranty (if applicable), please contact the manufacturer or installer; see the contact information provided in the system packaging.

# LIST OF THIRD-PARTY RIGHTS

## sha256 software

---

Copyright (C) 2012 Maxim Integrated Products

Permission is hereby granted, free of charge, to any person obtaining a copy of this software and associated documentation files (the "Software"), to deal in the Software without restriction, including without limitation the rights to use, copy, modify, merge, publish, distribute, sublicense, and/or sell copies of the Software, and to permit persons to whom the Software is furnished to do so, subject to the following conditions:

The above copyright notice and this permission notice shall be included in all copies or substantial portions of the Software.

THE SOFTWARE IS PROVIDED "AS IS", WITHOUT WARRANTY OF ANY KIND, EXPRESS OR IMPLIED, INCLUDING BUT NOT LIMITED TO THE WARRANTIES OF MERCHANTABILITY, FITNESS FOR A PARTICULAR PURPOSE AND NONINFRINGEMENT. IN NO EVENT SHALL MAXIM INTEGRATED PRODUCTS BE LIABLE FOR ANY CLAIM, DAMAGES OR OTHER LIABILITY, WHETHER IN AN ACTION OF CONTRACT, TORT OR OTHERWISE, ARISING FROM, OUT OF OR IN CONNECTION WITH THE SOFTWARE OR THE USE OR OTHER DEALINGS IN THE SOFTWARE.

Except as contained in this notice, the name of Maxim Integrated Products shall not be used except as stated in the Maxim Integrated Products Branding Policy.

## VC-1

---

THIS PRODUCT IS LICENSED UNDER THE VC-1 PATENT PORTFOLIO LICENSE FOR THE PERSONAL AND NON-COMMERCIAL USE OF A CONSUMER TO (i) ENCODE VIDEO IN COMPLIANCE WITH THE VC-1 STANDARD ("VC-1 VIDEO") AND/OR (ii) DECODE VC-1 VIDEO THAT WAS ENCODED BY A CONSUMER ENGAGED IN A PERSONAL AND NON-COMMERCIAL ACTIVITY AND/OR WAS OBTAINED FROM A VIDEO PROVIDER LICENSED TO PROVIDE VC-1 VIDEO. NO LICENSE IS GRANTED OR SHALL BE IMPLIED FOR ANY OTHER USE. ADDITIONAL INFORMATION MAY BE OBTAINED FROM MPEG LA, L.L.C. SEE [HTTP://WWW.MPEGLA.COM](http://www.mpegla.com)

# TABLE OF CONTENTS

<b>INTRODUCTION</b>	<b>iii</b>
<b>1 HANDLING PRECAUTIONS</b>	<b>1</b>
<b>2 PRECAUTIONS REGARDING INSTALLATION</b>	<b>4</b>
<b>3 PRECAUTIONS REGARDING OPERATION</b>	<b>7</b>
<b>4 PART DESCRIPTIONS</b>	<b>10</b>
<b>5 ACCESSORIES</b>	<b>11</b>
<b>6 ASSEMBLY AND INSTALLATION</b>	<b>12</b>
6-1 INSTALLING THE CABINET	13
6-2 FIXATION TO SITE	17
6-3 POWER SUPPLY AND OTHER CONNECTIONS	19
6-4 TURNING ON THE POWER	20
6-5 CONFIRMATION OF ASSEMBLY	22
6-6 APPLYING WARNING LABELS (EPILEPTIFORM SEIZURES)	23
<b>7 PRECAUTIONS WHEN MOVING THE MACHINE</b>	<b>24</b>
7-1 PRECAUTIONS WHEN MOVING FROM SITE	25
<b>8 GAME DESCRIPTION</b>	<b>26</b>
8-1 HOW TO PLAY	26
<b>9 EXPLANATION OF TEST AND DATA DISPLAY</b>	<b>33</b>
9-1 SWITCH UNIT AND COIN METER.	34
9-2 SYSTEM TEST MODE	35
9-3 SYSTEM INFORMATION	37
9-4 STORAGE INFORMATION	39
9-5 JVS TEST	41
9-6 MONITOR TEST	44
9-7 SPEAKER TEST	45
9-8 COIN ASSIGNMENTS	46
9-9 CLOCK SETTING	52
9-10NETWORK SETTING	54
9-11GAME TEST MENU	58
9-12BOOKKEEPING	59
9-13INPUT TEST	64
9-14OUTPUT TEST	65
9-15TICKET TEST	66
9-16GAME ASSIGNMENTS	67
9-17TICKET SETTINGS	69
9-18BONUS SETTINGS	70
9-19DIFFICULTY SETTINGS	71
9-20BACKUP DATA CLEAR	72
9-21TICKET ERROR	73



<b>10</b>	<b>CONTROLLER UNIT(S)</b>	<b>74</b>
	10-1 REMOVING THE CONTROLLER	75
<b>11</b>	<b>GRAPHICS DISPLAY</b>	<b>78</b>
	11-1 SAFETY PRECAUTIONS WHEN HANDLING THE MONITOR	78
<b>12</b>	<b>COIN HANDLING</b>	<b>84</b>
	12-1 CLEANING THE COIN SELECTOR	84
	12-2 FAULT FINDING	87
	12-3 ADJUSTING THE PRICE OF PLAY (EXCEL)	88
<b>13</b>	<b>LAMPS AND LIGHTING</b>	<b>92</b>
	13-1 COIN DOOR LAMP	92
	13-2 BILLBOARD LED LIGHTING	93
	13-3 HALF HOOP LED LIGHTING	95
	13-4 FULL HOOP LED LIGHTING	97
<b>14</b>	<b>PERIODIC INSPECTION</b>	<b>99</b>
	<b>TROUBLESHOOTING</b>	<b>101</b>
	15-1 TROUBLESHOOTING (WHEN NO ERROR MESSAGE IS SHOWN)	101
<b>16</b>	<b>GAME BOARD (NuSX)</b>	<b>104</b>
	16-1 HANDLING PRECAUTIONS	105
	16-2 GAME BOARD (NuSX) - LOCATION	106
	16-3 NuSX CLEANING	107
	16-4 REPLACING THE LITHIUM BATTERY	108
	16-5 NuSX CONNECTIONS	113
	16-6 ERROR CODES	114
<b>17</b>	<b>DESIGN RELATED PARTS</b>	<b>123</b>
<b>18</b>	<b>PARTS LIST</b>	<b>124</b>
<b>19</b>	<b>COLOUR CODE TABLE</b>	<b>145</b>
<b>20</b>	<b>SCHEMATIC DIAGRAMS</b>	<b>146</b>

This page intentionally left blank

# 1 HANDLING PRECAUTIONS

When installing or inspecting the machine, be very careful of the following points and pay attention to ensure that the player can enjoy the game safely.

Non-compliance with the following points or inappropriate handling running counter to the cautionary matters herein stated can cause personal injury or damage to the machine.

## WARNING

- Proceed with checks and tasks as indicated in these instructions. If instructions are not followed, or if tasks and/or checks are neglected, an electric shock or other very serious accident, even fatal accident can occur. Also, customers could be injured while operation the product.
- Before performing work, be sure to turn the power off. Performing the work without turning the power off can cause an electric shock or short circuit. In cases where work should be performed in the status of power on, this manual always states to that effect.
- To avoid an electric shock or short circuit, do not plug in or unplug quickly.
- To avoid an electric shock, do not plug in or unplug with a wet hand.
- Do not expose power cords or earth wires on the surface, (floor, passage, etc.) If exposed, the power cords and earth wires are susceptible to damage. Damaged cords and wires can cause an electric shock or short circuit.
- To avoid causing a fire or an electric shock, do not put things on or damage the power cords.
- When or after installing the product, do not unnecessarily pull the power cord. If damaged, the power cord can cause a fire or an electric shock.
- In case the power cord is damaged, ask for a replacement through where the product was purchased from or the office herein stated. Using the cord as is damaged can cause fire, an electric shock or leakage.
- Be sure to perform grounding appropriately. Inappropriate grounding can cause an electric shock.
- Be sure to use fuses meeting the specified rating. Using fuses exceeding the specified rating can cause a fire or an electric shock.
- Be sure that connections such as IC BD are made properly. Insufficient insertion can cause an electric shock.
- Specification changes, removal of equipment, conversion and/or addition, not designated by SEGA are not permitted.
- Failure to observe this may cause a fire or an electric shock. Non-compliance with this instruction can have a bad influence upon physical conditions of the players or the onlookers, or result in injury during play.
- SEGA shall not be held responsible for damage, compensation for damage to a third party, caused by specification changes not designated by SEGA.
- Do not perform any work or change parts not listed in this manual. Doing so may lead to an accident.

**⚠ WARNING**

- If you need to perform any work not listed in this manual, request work from the office indicated in this manual or the point of purchase, or inquire for details.
- Be sure to perform periodic maintenance inspections herein stated.
- Do not touch undesignated places. Touching places not designated can cause an electric shock or short circuit.
- Whenever any fasteners (e.g. screws, nuts) have been lost, be sure to use replacement fasteners with the proper dimensions as specified in this manual. If fasteners or any other fixings are used which do not correspond with the dimensions as outlined in this manual it may cause damage and/or separation of parts that may result in secondary accidents.
- When connecting a connector, check the direction carefully. Connectors must be connected in only one direction. If indiscriminate loads are applied in making connections, the connector to its terminal fixtures could be damaged, resulting in electric shock, short circuit or fires.

**STOP IMPORTANT**

For the IC board circuit inspections, only the use of a logic tester is recommended. Using a Multi Tester or General Purpose Tester may result in damage to IC Circuits.

Static electricity from your body may damage some electronics devices on the IC board. Before handling the IC board, touch a grounded metallic surface so that the static electricity can be discharged.

This video gaming cabinet utilises a motorised steering feedback system. Do not attempt to service this part or any other part in close proximity to the steering mechanism whilst power is applied.

Some parts are not designed and manufactured specifically for this game machine. The manufacturers may discontinue, or change the specifications of such general-purpose parts. If this is the case, SEGA cannot repair or replace a failed game machine whether or not a warranty period has expired.

## CONCERNING THE STICKER DISPLAY

This SEGA product has stickers attached describing the product manufacture No. (Serial No.) and Electrical Specifications. It also has a Sticker describing where to contact for repair and for purchasing parts. When inquiring about or asking for repairs, mention the Serial No. and Name of Machine indicated on the Sticker. The Serial Number indicates the product register. Identical machines could have different parts depending on the date of production. Also, improvements and modifications might have been made after the publication of this manual. In order to ensure you order the correct parts, mention the Serial No. when contacting the applicable places.

## CONCERNING WARNING DISPLAYS

This SEGA product has warning displays on stickers, labels and/or printed instructions adhered/attached to or incorporated in the places where a potentially hazardous situation could arise. The warning displays are intended for accident prevention for customers and for avoiding hazardous situations relating to maintenance and servicing work. Some portions of the cabinet contain high voltage and may cause accidents if touched. When performing maintenance, be very careful of the warning displays. It is especially important that any complex repair and replacement work not mentioned herein should be performed by those technical personnel who have knowledge of electricity and technical expertise.

In order to prevent accidents, caution any customer ignoring the warnings to cease and desist immediately.

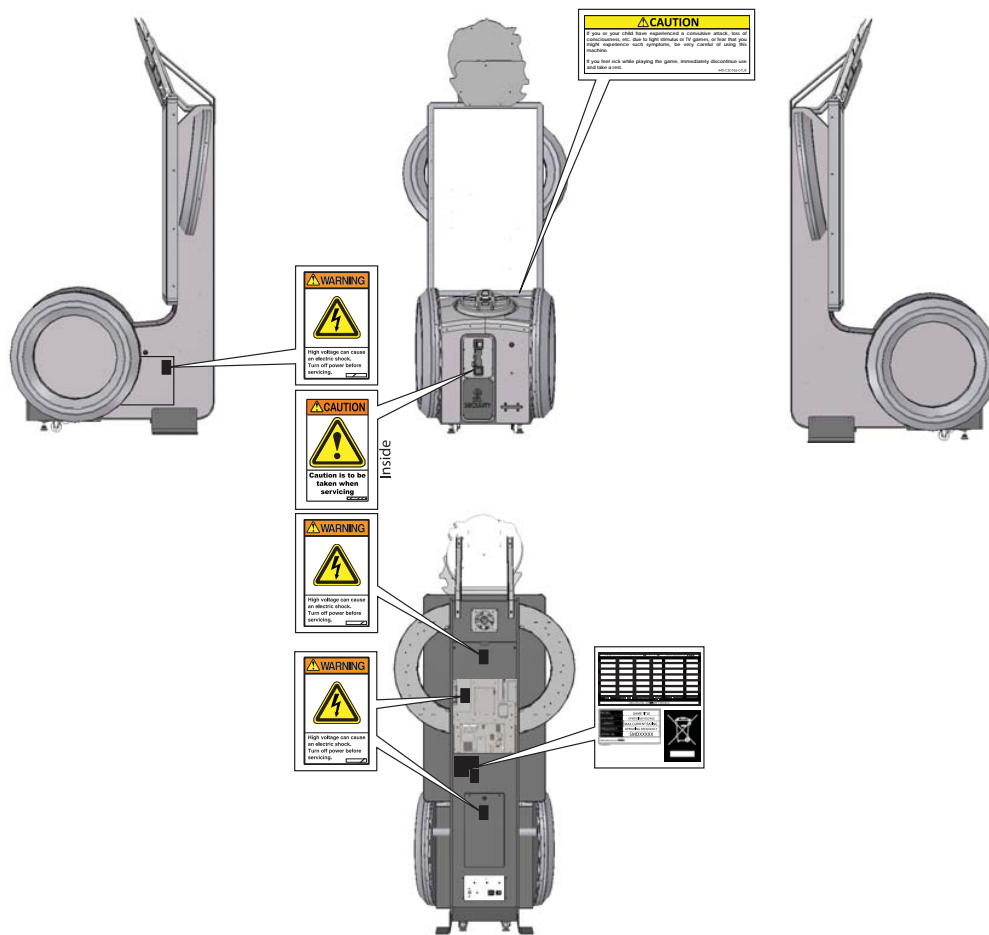

## 2 PRECAUTIONS REGARDING INSTALLATION

### WARNING

- This product is an indoor game machine. Do not install it outside. Even indoors, avoid installing in places mentioned below so as not to cause a fire, electric shock, injury and/or malfunction.
- Places subject to rain or water leakage, or places subject to high humidity in the proximity of an indoor swimming pool and/or shower, etc.
- Places subject to direct sunlight, or places subject to high temperatures in the proximity of heating units, etc.
- Places filled with inflammable gas or vicinity of highly inflammable/volatile chemicals or hazardous matter.
- Dusty places.
- Sloped surfaces.
- Places subject to any type of violent impact.
- Vicinity of anti-disaster facilities such as fire exits and fire extinguishers.
- Areas where the temperature exceeds the applicable temperature (ambient temperature) range of 5 to 30 degrees centigrade.

### LIMITATIONS OF USAGE

### WARNING

- Be sure to check the Electrical Specifications. Ensure that this product is compatible with the location's power supply, voltage, and frequency requirements. A plate describing Electrical Specifications is attached to the product. Non-compliance with the Electrical Specifications can cause a fire and electric shock.
- This product requires a breaker and earth mechanism as part of the location facilities. Using the product without these can cause a fire and electric shock.
- Ensure that the indoor wiring for the power supply is rated at 15 A or higher (AC single phase 100 V ~ 120 V area), and 7 A or higher (AC 220 V ~ 240 V area). Non-compliance with the Electrical Specifications can cause a fire and electric shock.
- Be sure to use an independent power supply equipped with an earth leakage breaker. Using a power supply without an earth leakage breaker can cause an outbreak of fire if a power surge occurs.
- Putting many loads on one electrical outlet can cause generation of heat and a fire resulting from overload.
- When using an extension cord, ensure that the cord is rated at 15 A or higher (AC 100 V ~ 120 V area) and 7 A or higher (AC 220 V ~ 240 V area). Using a cord rated lower than the specified rating can cause a fire and electric shock.

**STOP IMPORTANT**

Securing a safe area for operation as described in this manual will ensure safe operation for players and observers.

SEGA shall not be held responsible for damage or compensation for damage to a third party, resulting from the failure to observe this instruction.

OPERATION AREA

**⚠ WARNING**

For the operation of this machine, secure a minimum area of 1.7m (W) x 2.0m (D).

Be sure to provide sufficient space specified in this manual. Do not allow objects to block the ventilation ports. It can cause generation of heat and a fire.

Sufficient space either side of the playing area must be allowed for the player to enter or exit the game safely.

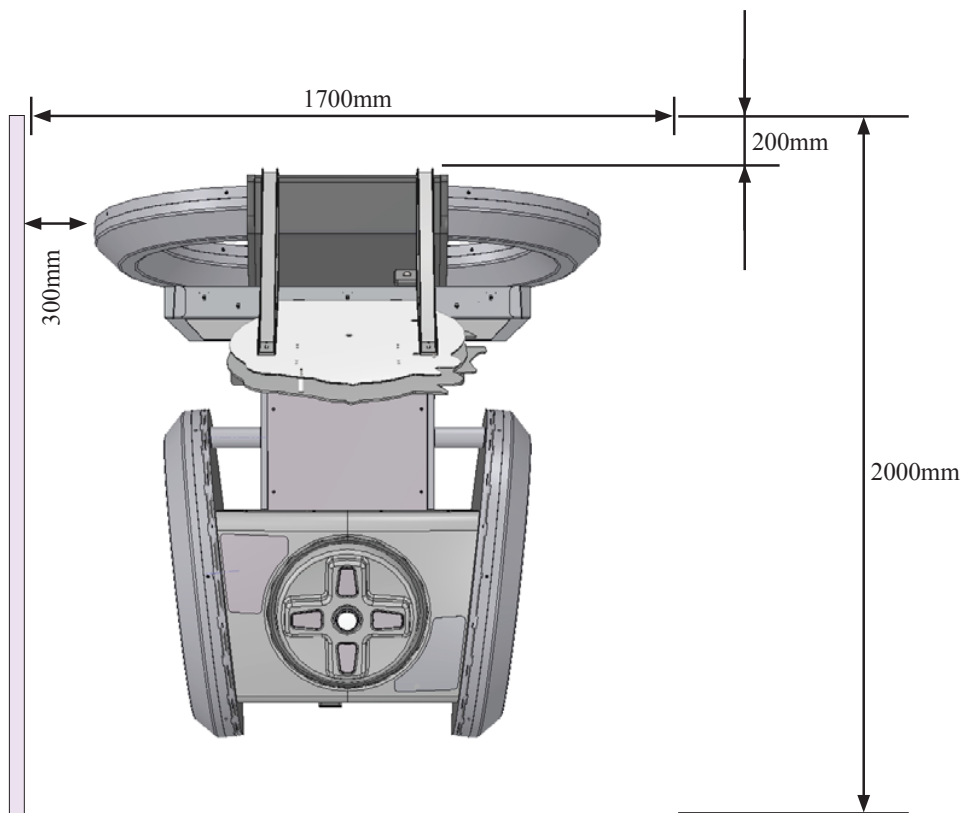



**STOP IMPORTANT**

To install this product, the entrance must be at least 1.2m in width and 2.1 m in height (without Assy Billboard) and 2.7m (with Assy Billboard).

Do not attempt to push/pull whilst holding onto the Assy Billboard. This may result in part damage and or personal injury.

**2 PRECAUTIONS REGARDING INSTALLATION LOCATION**

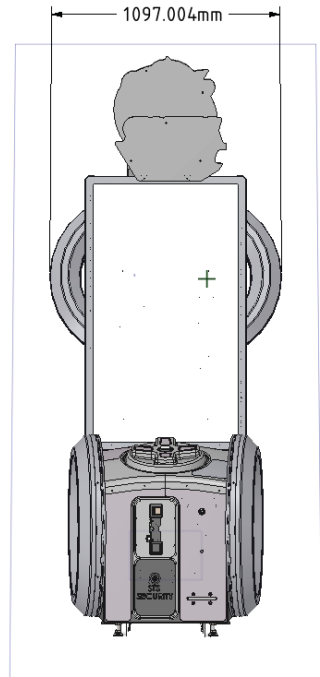
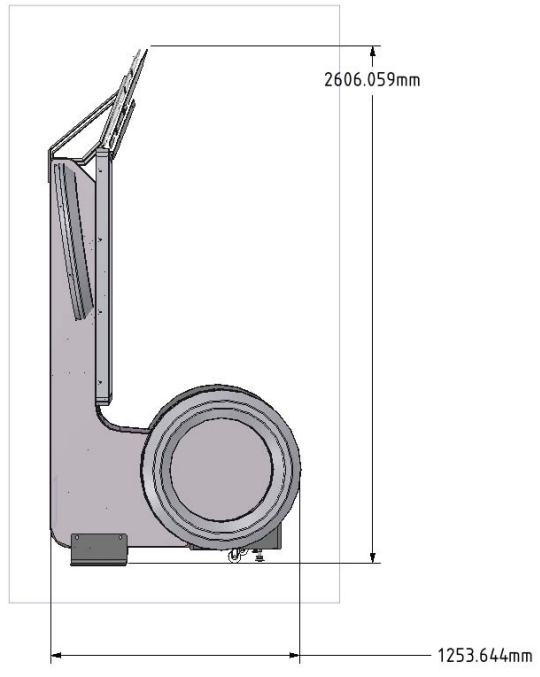
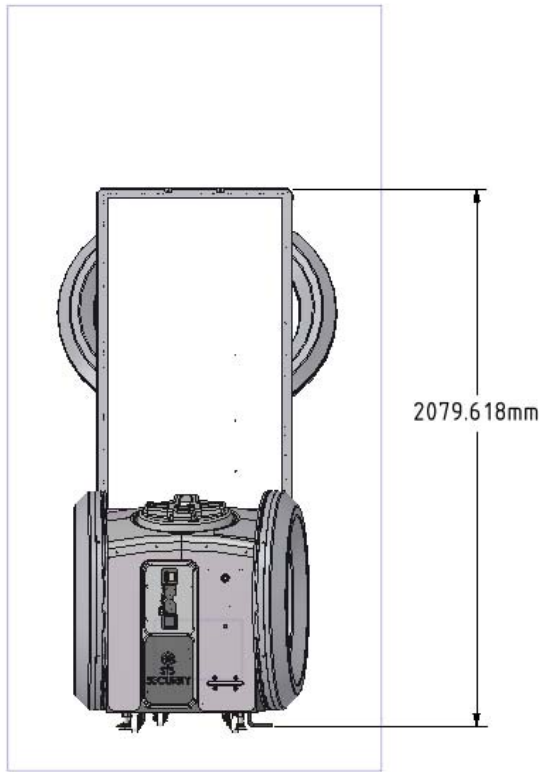

### 3 PRECAUTIONS REGARDING OPERATION

To avoid injury and trouble, be sure to pay attention to the behavior of visitors and players.

#### WARNING

In order to avoid accidents, check the following before starting the operation:

- To ensure maximum safety for the players and the customers, ensure that where the product is operated has sufficient lighting to allow any warnings to be read. Operation under insufficient lighting can cause bodily contact with each other, hitting accident, and/or trouble between customers.
- Be sure to perform appropriate adjustment of the display (LCD, Plasma, CRT or Projector). For operation of this machine, do not leave monitor's flickering or deviation as is. Failure to observe this can have a bad influence upon the players' or the customers' physical conditions.
- It is suggested to ensure a space allowing the players who feel sick while playing the game to take a rest.
- Check if all of the adjusters are in contact with the surface. If they are not, the Cabinet can move and cause an accident.

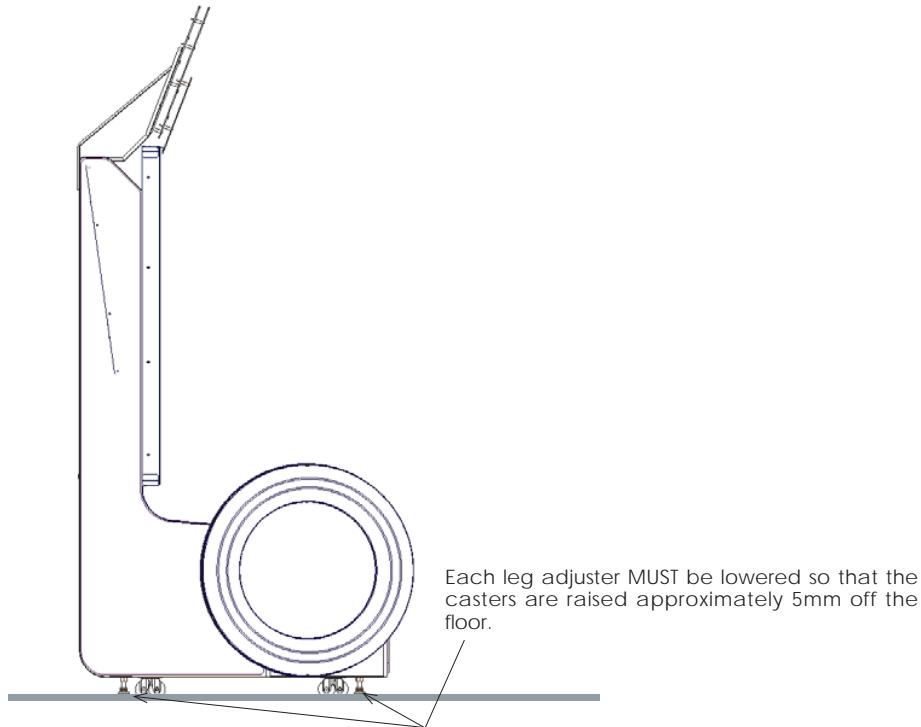

- Do not put any heavy item on this product. Items, if placed on this product may fall and cause injury to the player / observer.
- Do not climb on the product. Climbing on the product can cause falling down accidents. To check the top portion of the product, use a step ladder.

**⚠ WARNING**

- To avoid electric shock, ensure that all covers and panels are undamaged and fitted. Do not operate with covers removed.
- To avoid electric shock, short circuit and/or parts damage, do not put the following items on or in the periphery of the product.  
Flower vases, flowerpots, cups, water tanks, cosmetics, and receptacles/containers/vessels containing chemicals and water.

**⚠ CAUTION**

- To avoid injury, be sure to provide sufficient space by considering the potentially crowded situation at the installation location. Insufficient installation space can cause making bodily contact with each other, hitting accidents, and/or trouble between customers.
- Everyday when cleaning the Controller, inspect the controller and make sure that there are no cracks in the surface, and that the fastening screws are not loose. If the game is played with cracks or loose screws, it can cause injuries to the player.
- Do not allow more than one person to play the game at any one time.

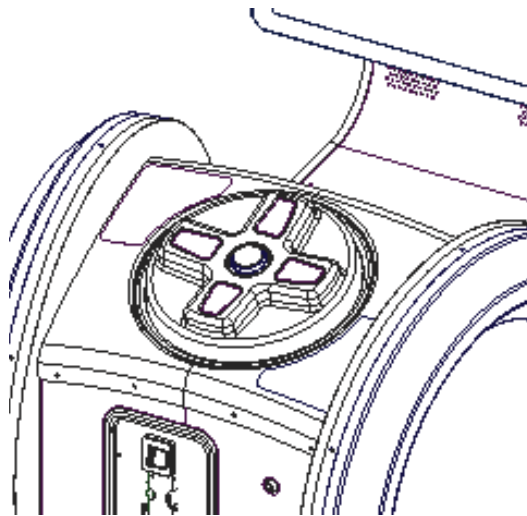

Frequent checks to the controller for and signs of dmaage or wear and tear.

It is recommended that wet towels (paper towels) be provided.

## DURING OPERATION (PAYING ATTENTION TO CUSTOMERS)

To avoid injury and trouble, be sure to constantly give careful attention to the behavior and manner of the visitors and players.

### WARNING

- For safety reasons, do not allow any of the following people to play the game.
- Those who have high blood pressure or a heart problem.
- Those who have experienced muscle convulsion or loss of consciousness when playing video games, etc.
- Those who have neck or spinal cord problems.
- Those who are intoxicated or under the influence of drugs.
- Pregnant women.
- Those who are not in good health.
- Those who do not follow the attendant's instructions.
- Those who cannot grasp the Control Unit securely because of immobility in fingers, hands or arms.
- Persons who disregard the product's warning displays.
- This product is intended for a single player only. Having two or more persons simultaneously playing this product can result to injury to the player and possible damage to the product.
- Even players who have never been adversely affected by light stimulus might experience dizziness or headache depending on their physical condition when playing the game.
- Small children are especially likely to experience these symptoms. Caution guardians of small children to keep watch on their children during play.
- Instruct those who feel sick during play to have a medical examination.
- To avoid injury from falls and electric shocks due to spilled drinks, instruct the player not to place heavy items or drinks on the product.
- To avoid electric shocks and short circuits, do not allow customers to put hands and fingers or extraneous matter in the openings of the product or small openings in or around the doors.
- To avoid falls and resulting injury, immediately stop the customer from leaning against or climbing on the product, etc.
- To avoid electric shock and short circuit, do not allow customers to unplug the power plug without a justifiable reason.
- Instruct the guardians of small children to keep an eye on their children.
- Children cannot sense danger. Allowing small children to get near a player who is playing the game could result in the children being bumped, struck or knocked down.

## 4 PART DESCRIPTIONS

### 4 PART DESCRIPTIONS

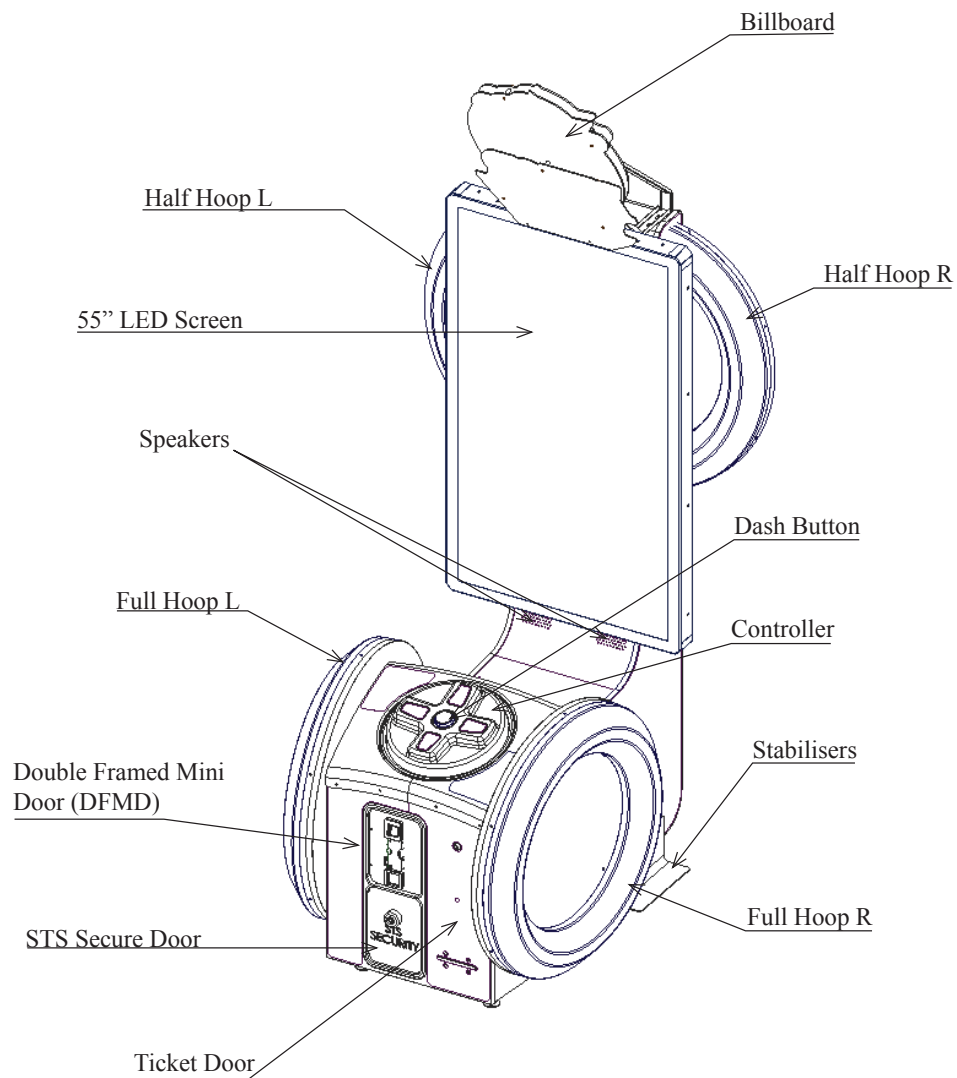

# 5 ACCESSORIES

Confirm that the accessories listed in the table below are present when setting up the product. Accessories marked “Spare” in the note column are consumable items but included as spares.

DESCRIPTION: OWNER'S MANUAL  
Part No. (Qty.): 420-0024-01UK(1)

Parts not labeled with part numbers are as yet unregistered or cannot be registered. Be sure to handle all parts with care, as some parts are not available for purchase separately.



440-CS0186UK  
Sticker C Epilepsy Multi (1)

KEY MASTER  
220-5575-01UK (2)  
For operating/closing the doors

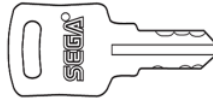

KEY  
(2)

For the cashbox door  
(Located inside the coin chute door at time of shipment)

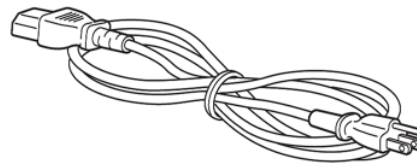
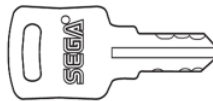

POWER CORD  
LM1227 (1) <UK>  
LM1226 (1) <EU>  
For installation. See chapter 6.

## **6** ASSEMBLY AND INSTALLATION

### **WARNING**

- Perform assembly work by following the procedure herein stated. Failure to comply with the instructions can cause electric shock.
- Perform assembly as per this manual. Since this is a complex machine, incorrect assembling can cause an electric shock, machine damage and/or improper functioning as per specified performance.
- When assembling, more than one person is required. Depending on the assembly work, there are some cases in which working by one person alone can cause personal injury or parts damage.
- Ensure that connectors are properly connected. Improper connections can cause electric shock.
- Be careful not to damage the wires. Damaged wires may cause electric shock or short circuit or present a risk of fire.
- Do not unnecessarily push the display screen.
- This work should be carried out by site maintenance personnel or other qualified professionals. Work performed by non-technical personnel can cause a severe accident such as electric shock. Failing to comply with this instruction can cause a severe accident such as electric shock to the player during operation. If no one with proper technological expertise is available, request service from the office indicated in this document or the point of purchase so as to ensure safety.
- Provide sufficient space so that assembling can be performed. Performing work in places with narrow space or low ceiling may cause an accident and assembly work to be difficult.
- To perform work safely and avoid serious accident such as the cabinet falling down, do not perform work in places where step-like grade differences, a ditch, or slope exist.
- This product does not use any connectors other than those connected to and used by the game board when it leaves the factory. Do not needlessly connect wires to unused connectors. This could lead to overheating, generation of smoke and burn related injuries.

### **CAUTION**

- Handle molded parts with care. Excessive weight or pressure may cause them to break and the broken pieces may cause injury.
- To perform the operation safely and accurately you must use a safe, steady footstool or stepladder. Working without this may lead to a fall and possible injury.



## 6-1 INSTALLING THE CABINET

### CAUTION

- To perform work safely and securely, be sure to prepare a step which is in a safe and stable condition. Performing work without using a step may lead to injury or damage to components.

Tools required for installation:

Allen Key (M8) (Not Supplied)  
- Attaching ASSY BILLBOARD to cabinet  
- Attaching BKT CABI LOWER

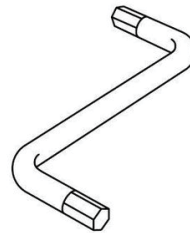
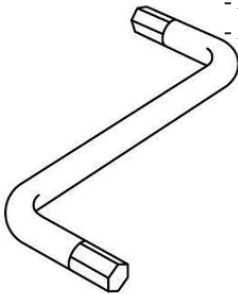

Allen Key (M4) (Not Supplied)  
- Attaching ASSY Billboard to cabinet

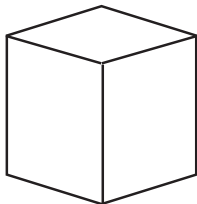

Step or Ladders  
- Aid in fixing Billboard and Billboard Panel.

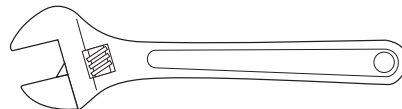

Adjustable Wrench  
- Secure cabinet into position.

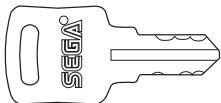

KEY  
- Gain access to Coin Tower

## 6-1-1 INSTALLING THE ASSY BILLBOARD

- 1 The Billboard is separately wrapped along with the cabinet and needs to be applied prior install..

Assy Billboard - SND 0500UK

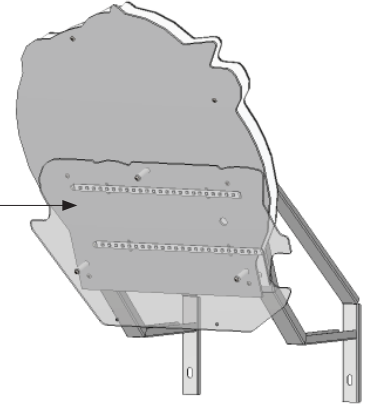

- 2 Using a Step Ladder or Stool, raise the ASSY BILLBOARD and align with the fixing holes at the top of the cabinet.

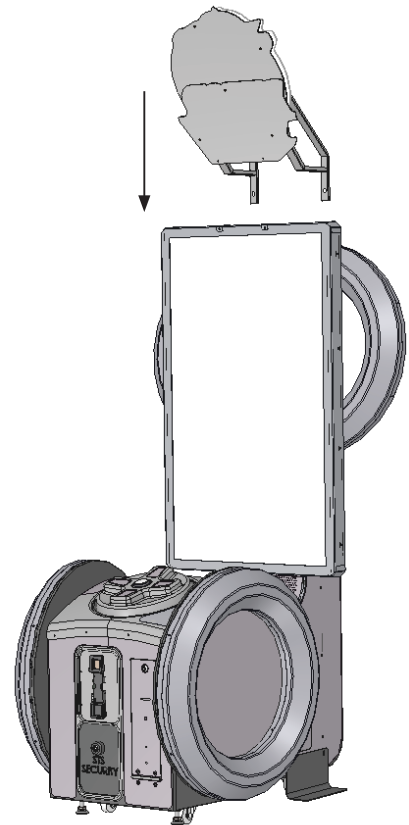

- 3** Once in position, secure the ASSY BILLBOARD at the rear of the cabinet using (6) M8x25 SKT CAP Screws and washers (029-B00825-0B/060-S00800-0B/068-852216-0B)

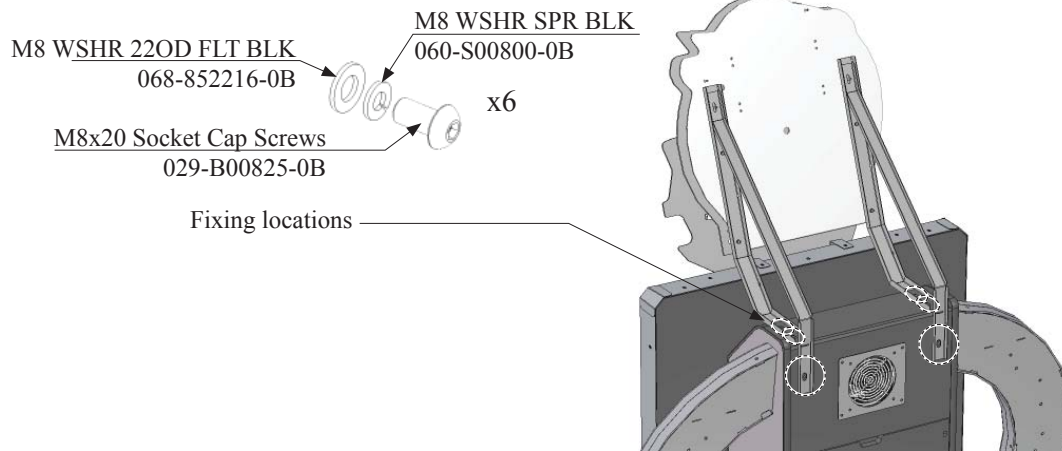

- 4** Fit and secure the remaining 2 fixings at the front of the ASSY BILLBOARD using (2) M4x12 SKT CAP Screws and washers.

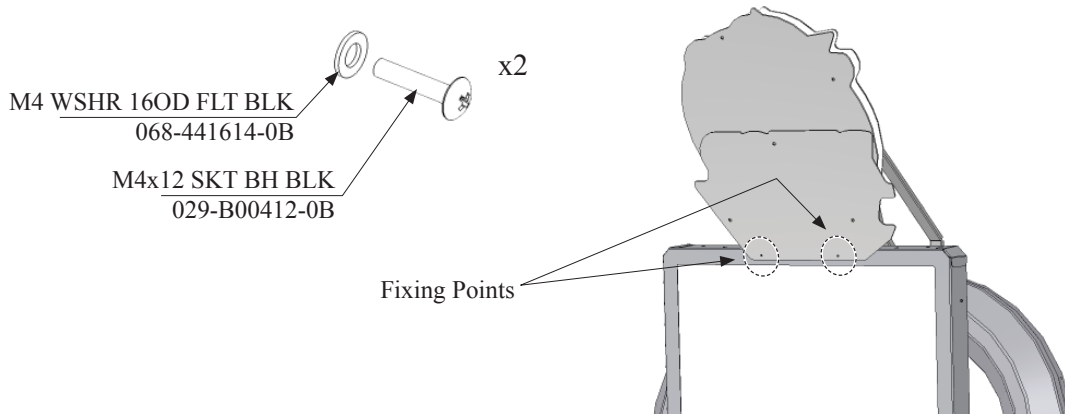

- 5** Once the ASSY BILLBOARD is secure, make the connection to the cabinet where shown. Make sure that there are no trailing cables. Any loose cables must be secure to the ASSY BILLBOARD brackets.

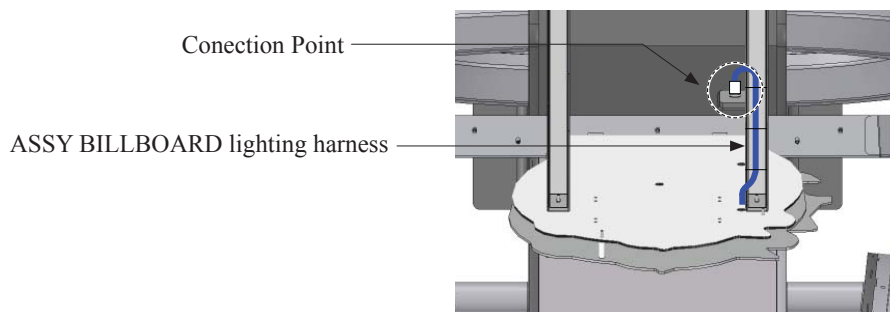

**⚠ WARNING**

- Due the nature and the design of the cabinet it is **IMPORTANT** that the **CABINET LOWER BRACKETS** are fitted to both sides of the cabinet. These brackets, when fitted provide the cabinet with extra stability. Failing to apply these brackets to the cabinet may render the cabinet unstable.

BKT CABI LOWER (2)  
PD-1002UK

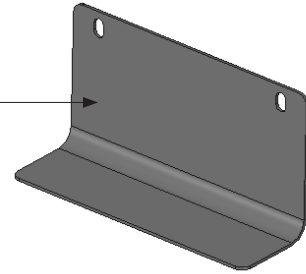

- 6** Apply the BKT CABI LOWER to both side of the cabinet as shown. Secure using (4) M8x25 SKT CAP Screws and washers (029-B00825-0B/060-S00800-0B/068-852216-0B)

M8 WSHR 22OD FLT BLK  
068-852216-0B

M8 WSHR SPR BLK  
060-S00800-0B

M8x20 Socket Cap Screws  
029-B00825-0B

x4

BKT CABI LOWER (2)  
PD-1002UK

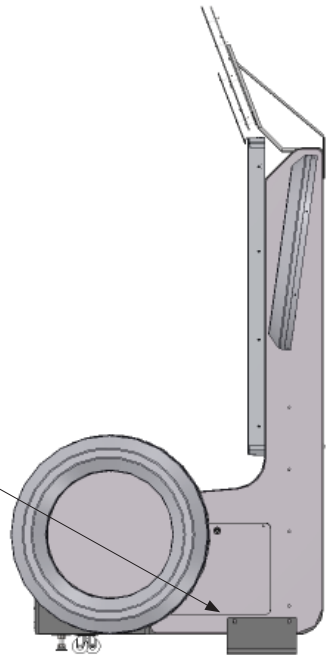

Fixing Points

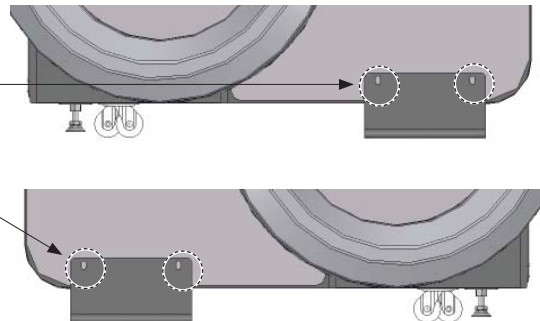

## 6-2 FIXATION TO SITE

### WARNING

- Make sure that all the adjusters contact the floor. Otherwise the cabinet could move, causing an accident.
- Provide a ventilation space at least 20cm wide behind the cabinet. There are ventilation holes on the back of the cabinet. Do not block the ventilation holes. Doing so could trap heat inside resulting in fire. It could also result in equipment damage or cause parts to become exhausted prematurely.

The product is equipped with 4 casters and 4 adjusters.

When installation position / site has been determined, have the adjusters come in direct contact with the floor. Establish a gap of about 5 mm between the floor and the casters and adjust the unit so that it will remain level.

1 Move the product to the installation site.

2 Bring the adjusters into direct contact with the floor. Use a wrench to align the height of the adjusters until the cabinet is perfectly level.

3 After setting, turn adjuster nuts upwards to tighten them and secure adjuster heights.

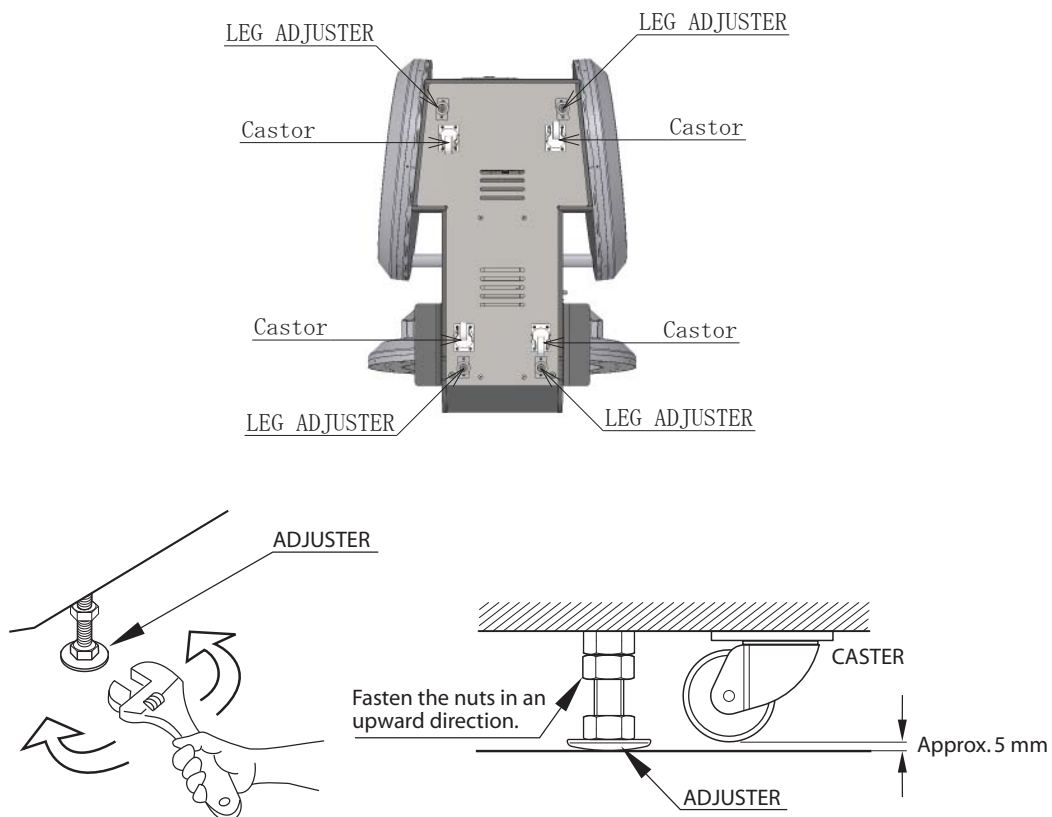

**! WARNING**

- Provide a ventilation space at least 20cm wide behind the cabinet. There are ventilation holes on the back of the cabinet. Do not block the ventilation holes. Doing so could trap heat inside resulting in fire. It could also result in equipment damage or cause parts to become exhausted prematurely.

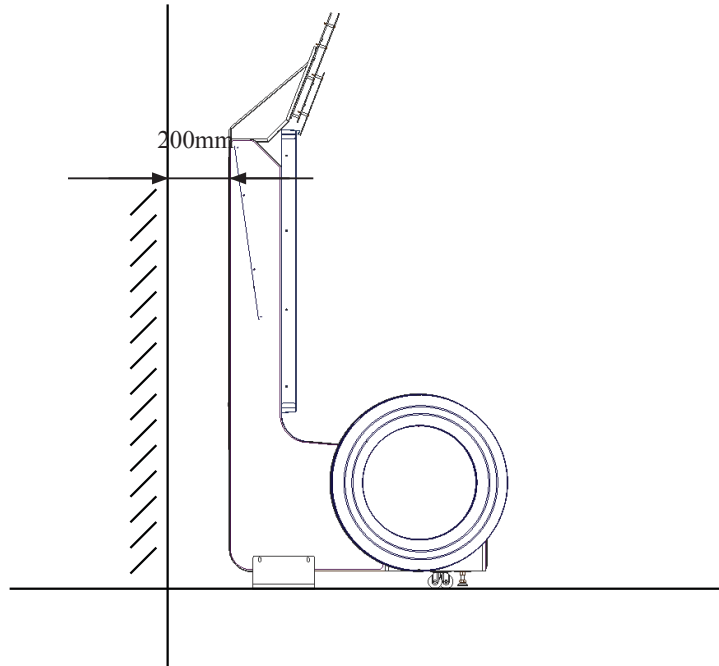

Leave a 200mm gap for ventilation

## 6-3 POWER SUPPLY AND OTHER CONNECTIONS

### WARNING

- Use the power supply equipped with an earth leakage breaker. Use of power supply without such a breaker could result in fire if there is a current leakage.
- Have available a securely grounded indoor ground terminal. Without proper grounding, customers could be electrocuted and product operations might not always be stable.
- Do not expose the power cord or ground wire. If these are exposed, customers could stumble over them, for instance, and easily damage them. Additionally, if these lines are damaged, there could be a risk of electrical shock or short circuit. Set these lines at locations where they will not interfere with customer traffic, or attach covers to them.
- After laying out the power cord on the floor, be sure to always protect it. If the power cord is left exposed, it can easily be damaged, resulting in electrical shock.

- 1 Confirm that the main switch is at OFF.

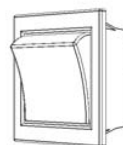
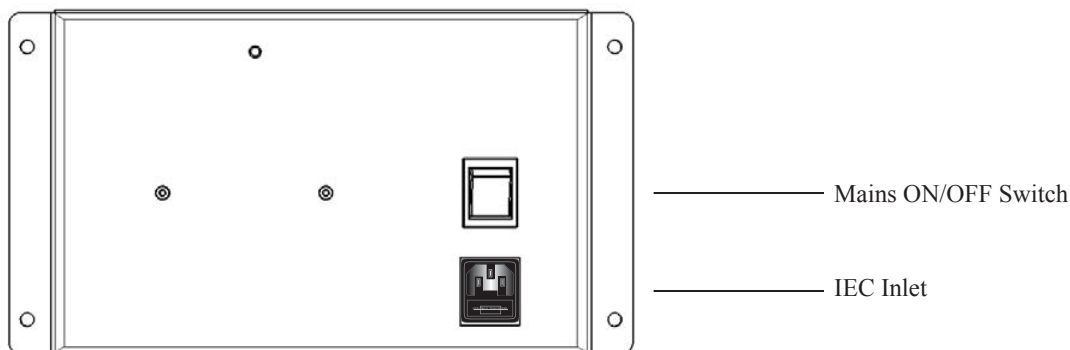

Mains Switch shown in OFF position



- 2 Fully insert the power cord connector on the side opposite the power plug into the AC unit IEC inlet. Insert the power cord plug into the outlet.
- 3 The power code is laid out indoors. Protect the power cord by attaching wire cover to it.

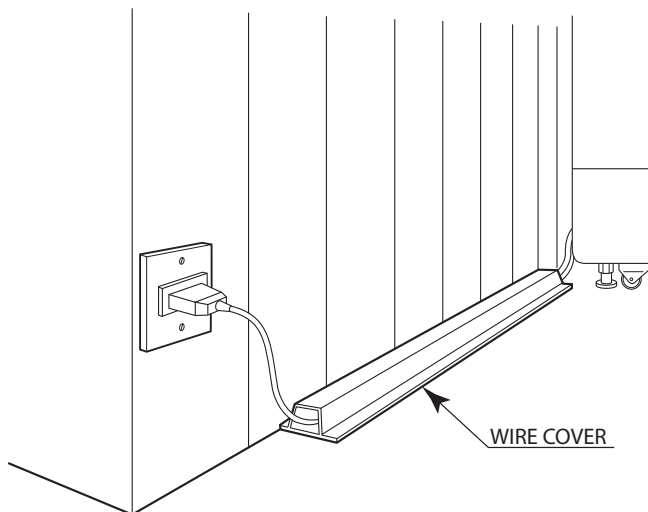

## 6-4 TURNING ON THE POWER

Set the main switch of the AC unit to ON and engage the power.

When you turn on the power, the billboard LED lights will come on.

After the SEGA LOGO start up screen is displayed on the LCD screen, the Advertise (Attract) Mode will start.

The decorative LEDs within the FULL and HALF HOOPS will scroll through a variation of colours.

Start up sounds are output from the speakers on the left and right of the cabinet together with display of the SEGA startup screen.

Even when the power source has been cut off, credit count, ranking data, game settings and bookkeeping data are kept stored in the product. However, fractional coin counts (inserted coins that do not amount to one credit) and bonus adder counts are not kept.

## COMPONENTS WHICH CHANGE STATE WHEN POWER IS APPLIED

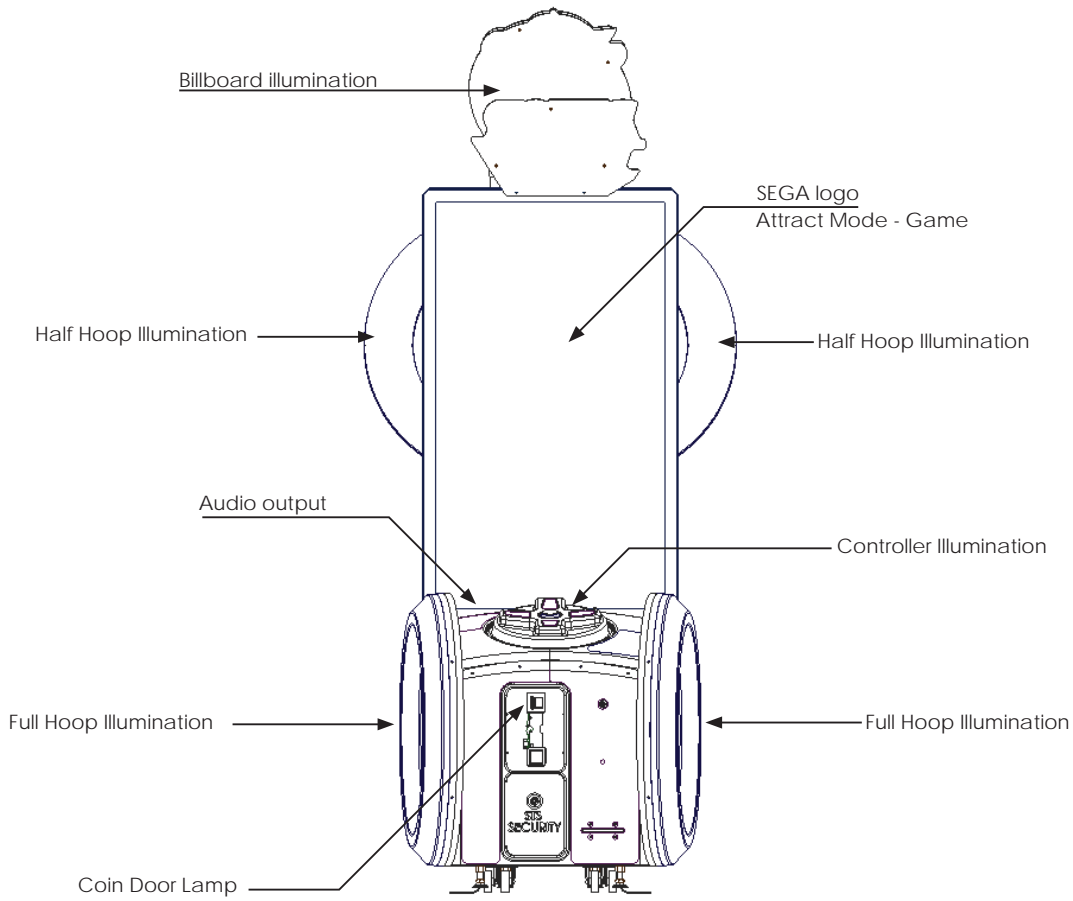

## 6-5 CONFIRMATION OF ASSEMBLY

In the test mode, ascertain that the assembly has been made correctly and IC Board is satisfactory.  
In the test mode, perform the following test: (refer to chapter 9).

### 9-13 INPUT TEST

This menu is used to test the system inputs such as steering, pedals and buttons. To implement the test, press each device that is listed and check the results on screen.

### 9-14 OUTPUT TEST

This menu is used to test the system outputs such as Lamps and LED.

### 9-8 COIN ASSIGNMENTS

As this system utilises a Credit Board PCB, it is important that the setting remain 1 COIN 1 PLAY. Deviation from this setting when using the Credit Board PCB can result in unusual credit outputs.

### 9-15 TICKET TEST

This menu will allow you to check the output of tickets. (Not required in Amusement Only Mode)

### 9-16 GAME ASSIGNMENTS

This test is required to configure the game according to its location.

## 6-6 APPLYING WARNING LABELS (EPILEPTIFORM SEIZURES)

### CAUTION

- The operator **MUST** apply the Epileptiform Seizure Label to this product. Failing to apply this label may result in the player/observer suffering from a photosensitive seizure. Warning the potential player/ observer of this before the start of a game may prevent such accidents.
- It is also important to apply the correct language label for each location. There are nine (9) different language labels - please apply the label which matches your location. (ENGLISH is fitted by default).

### IMPORTANT

Application of any warning labels must be placed in a location which is easy for the player/observer to read. Please follow the instructions below and apply the label in the location stated.

The Epileptiform Seizure label is supplied in 9 different languages. Please choose the label which matches your language location.

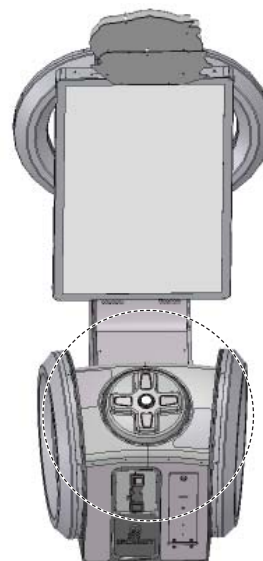

Apply the label to the top right hand corner of the Control Panel. This location is unobstructed and can be easily read by players and observers alike.

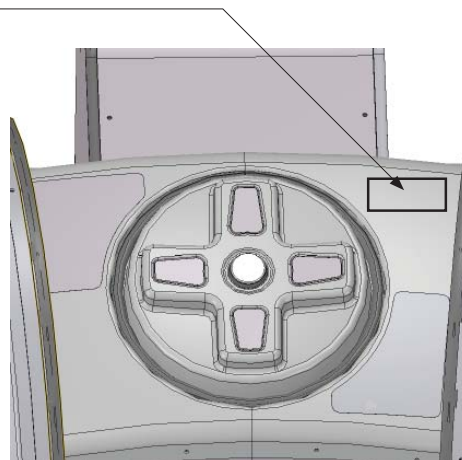

## **7** PRECAUTIONS WHEN MOVING THE MACHINE

**7**

PRECAUTIONS WHEN MOVING THE MACHINE

### **WARNING**

- Always disconnect the power cable before moving the product. If it is moved with the power cable connected, the cable could be damaged, causing fire or electric shock.
- To move the unit over the floor, pull in the adjusters and have the casters contact the floor. Remove the **CABINET LOWER BRACKETS**. While moving the unit, be careful that the casters do not roll over the power cord or the ground wire. If cord or wire is damaged, there could be electrical shocks and/or short circuits.
- When crossing a sloped or stepped area, always have the machine travel lengthways with the screen towards the slope. Travelling with the machine in a sideways position could result in the machine falling over onto its side. Always use a minimum of two people working together plus lifting apparatus to accommodate sloped areas or stairs.
- To lift up the cabinet, hold it at the bottom at the designated lifting points. If you hold it anywhere else, the weight of the cabinet could cause damage to parts or attachments, resulting in injury.
- Do not push the cabinet from the side when moving. Pushing from the side as it may result in the cabinet falling over.

**STOP**

### **IMPORTANT**

- When moving the cabinet, do not grip or push the Billboard Plate. Doing so could deform or damage the part.
- When moving the cabinet, do not grip or push the HOOPS. Doing so could deform or damage the part.
- When moving the cabinet, do not grip or push the Controller. Doing so could deform or damage the part.
- If moving through a door or place with a low ceiling such as an elevator, you should take apart the billboard and billboard plate.

## 7-1 PRECAUTIONS WHEN MOVING FROM SITE

### STOP IMPORTANT

- When moving the cabinet, do not grip or push the Billboard Plate. Doing so could deform or damage the part.
- If moving through a door or place with a low ceiling such as an elevator, you should take apart the billboard and billboard plate.

Detailed instructions for removing the Assy Billboard and Billboard Plate can be found in Chapter 6 of this manual. Please follow these instruction in reverse order for removal.

Remove the Billboard and Billboard Plate when transporting the machine in and out of buildings or when passing through areas with low ceilings.

Ensure that the casters come into contact with the floor before moving.

Remove the Lower Stability Brackets when moving over greater distances.

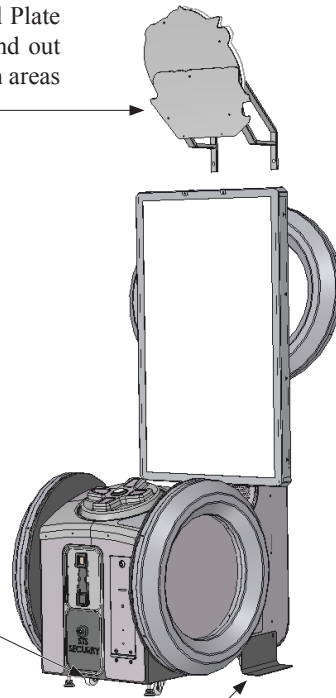

## 8 GAME DESCRIPTION

### 8-1 HOW TO PLAY

#### GAME INTRODUCTION

This machine has two game modes. One is "Ticket Redemption, the other is "Amusement only" (Fun for play, no tickets).

#### (Redemption /Amusement mode)

1. After the coins are inserted, available credits will display at the bottom of the screen.
2. After required coins are inserted, the text will change from "Please insert coins" into "Please press start button". The start button on the cabin will be flickering.
3. Coin system can accumulate up to 24 credits. Credits beyond 24 will not be counted and not returned to player, but will be recorded by system internal counter.
4. "INSERT COIN(S)" / "INSERT MORE COIN(S)" may change to "SWIPE CARD TO PLAY". Based on the difference of test mode settings,

\*If you set mode setting "AUTO START ON" , Players can immediately play this game without pressing start button when credits are available to play.

#### GAME SCREEN

Below shows each game screen mode of redemption mode and arcade mode.

##### Redemption mode



## Arcade mode



## Basic Rules

Player's target is to reach goal. For that, some actions are required.

## Redemption/Arcade

1. Player's character has limited lives for playing game. \*
2. Character automatically go forward when this game starts
3. **Reach to the goal area by controlling the character.**
4. Player character will encounter difficulties like objects and creatures on the route.
5. Otherwise, There are some items that support character.
6. Character's lives are reduced when player fails to avoid certain objects or hit against creatures without accumulating rings.
7. Game is over when there is no left lives.

\*Under the redemption mode, life is fixed as one.



**Basic Control**

Take action with D-pad and button not only for avoiding crashing but also attacking the creatures.

1. Player can use a D-Pad and a Dash button for some action.
2. Each direction on D-Pad means take action like below.

Up : Jump

Left : Move to Left

Right : Move to Right

Down : Rolling(Lower position and attack with rolling)

3. Character can dash with pressing start/dash button when dash meter is fully charged. Dash means not only does the character speed up but also protected from any trouble.

**Rings, Items, Objects**

- **Rings**

- Dash meter will increase when your character collects rings. When the Dash meter is full, Player can make their character Dash using the DASH ACTION button.

- **Items**

- There are items on route. For instance, bonus rings which help in protecting your character etc.

- **Objects**

- There are some structures made by wood, stones on the route.
- Players can avoid crashing into these with using D-pad/Dash.
- If a character crashes into an object, the character lives will be reduced.

- **Creatures**

- A Player can avoid or beat creatures when Rolling or by pressing the DASH button.
- When character crash into creatures, the character will lose all their rings. If a character crashes with creatures without rings, the character lives will be reduced.

## **Mini Game**

- As the game continues, There is an area where the character automatically jump to sky.
- This is called a “Mini Game” where "ACTION!" will take place.
- A players have to turn D-Pad directions on screen information within limited time.
- If the player succeed in action, he/she can gain extra score bonus.
- If the player fail in action, he/she can't gain it.



[ACTION! screen]

## **Boss Battle**

At the end of the level, there will be an Eggman boss to fight against. Just like in mini game, a player needs to turn D-Pad directions or press the button on screen information.

If the player succeed in action, BOSS life gauge will decrease. When the BOSS life gauge decreases to 0, it is defeated.

### Summary of Redemption mode.

#### - Flow

1. A player will select his/her character.\*
2. After character selected, each stage will automatically be selected.

\*If you set mode setting "SKIP SELECT SEQUENCE ON", a player character is automatically selected.

3. Game starts
4. The Player can get tickets with going through check points and collecting rings.
5. The Player can collect tickets when reaching each Checkpoint or the Goal.
6. The player can also get bonus ticket when he/she collects rings.

#### - Mini Game

- As the game plays along, mini game sequence will start. The player has to turn D-Pad directions and follow on-screen information.

#### - Boss Battle(Super Bonus)

- If you set "SUPER BONUS ON" on the test mode, Boss battle sequence will start after player pass through the goal. The player can get super bonus if he/she defeats the boss.
- Boss battle is a timing game which involves pressing the DASH button.



[Redemption mode: Boss Battle]



[Redemption mode: Super Bonus]

**Closing credits -** When a player completes the super bonus, Closing credits will show on screen.

### Summary of Arcade mode.

#### - Flow

1. A player will select his/her character.\*
2. After a character is selected, the player will choose a difficulty and stage.
3. Game starts
4. This mode has time limits. If time is over, it means game over.
5. Amusement mode has various scores for different skills of players.
6. Daily top 10 high score rank will show on attract mode.

#### - Mini Game

- As game plays along, mini game sequence will start. The player has to turn D-Pad directions on screen information.

#### - Boss Battle

- If a player reaches the goal point, the Boss Battle will start.\* Player can get good score by the beating boss.
- Boss Battle has only one chance. If player misses, Game will be over.
  - Amusement Boss Battle has two sequence.
    1. Missile Battle - Objective is to avoid the missiles which Eggman fires
    2. Action Battle - It has 3 time battle. The first and second battle as same as mini game(D-pad), but the last 3<sup>rd</sup> battle is timing action as same as redemption boss battle.



[Boss Battle 1 Missile Battle]



[Boss Battle 2 Action Battle]

If a player defeat Eggman, he/she can gain bonus scores.

## Ranking

Amusement mode has daily ranking system. Players can join a daily top 10 ranking where he/she can enter his/her name within 3 characters.

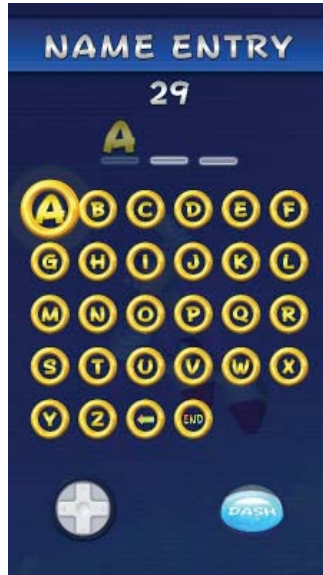

[Name entry]

### —Closing credits

If a player defeats Eggman and also gain the top score of the day, closing credit will show on the screen.

## 9 EXPLANATION OF TEST AND DATA DISPLAY

Perform tests and data checks periodically by manipulating the TEST Button and SERVICE Button in the cabinet. Follow the instructions in this chapter to conduct checks when the game machine is first installed, when money is being collected, or when the game machine does not operate properly.

Shown overleaf are the tests and screens to be used for different problems.

### WARNING

- When installing 2 of more cabinets which are networked together. The GAME SETTINGS which are adjusted within the first cabinet are reflected throughout all cabinets within that network.

### IMPORTANT

- When changing the game configuration within the TEST MODE, be sure to exit all screens in the correct manner by choosing exit. DO NOT turn the machine ON/OFF to resume game. Changes WILL NOT take effect unless the correct method is used.

## 9-1 SWITCH UNIT AND COIN METER.

### WARNING

Never touch places other than those specified. Touching places not specified can cause electric shock and short circuit accidents.

### IMPORTANT

- Adjust the sound to the optimum volume, taking into consideration the environmental requirements of the installation location.
- Removing the Coin Meter circuitry renders the game inoperable.

#### 9-1-1 SWITCH UNIT

Open the coin chute door, and the switch unit shown will appear.  
The functioning of each SW is as follows:

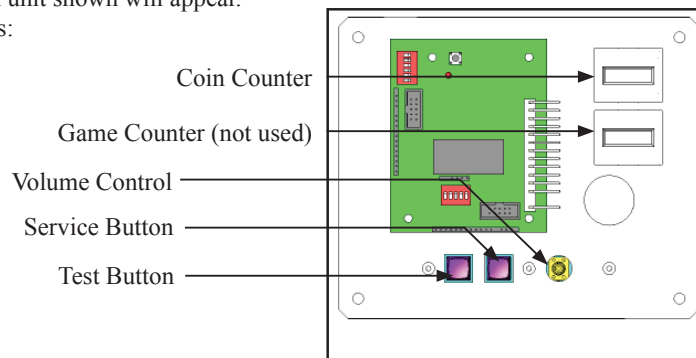

9-1-1 FIG. 01

TEST Button (TEST):	For the handling of the Test Button, refer to the following pages.
SERVICE Button (SERVICE):	Gives credits without registering on the coin meter.
Sound Volume Switch (SOUND VOLUME):	Adjust sound volume for all of the machines' speakers.
Coin Counter	Counts and displays coins in \$0.10 units.
Game Counter	Counts games played

## 9-2 SYSTEM TEST MODE

### STOP IMPORTANT

The details of changes to Test Mode settings are saved when you exit from each Test Mode by selecting EXIT. Be careful because if the power is turned off before that point, changes to the settings will be lost.

### STOP IMPORTANT

- Settings other than coin settings are saved at the point the TEST Button is pressed after selecting EXIT at each TEST screen. Be careful because if the power is turned off before that point, changes to the settings will be lost.
- Coin settings are saved at the point the TEST Button is pressed after selecting EXIT at the SYSTEM TEST MODE screen. Be careful because if the power is turned off before that point, changes to the settings will be lost.
- This manual does not explain the GAME TEST MODE that is used for such as setting the difficulty of games. Refer to the manual for each game.
- The TEST screen display may change depending on the OS version.

SYSTEM TEST MODE can be used to check the information or the operation of the Nu, adjust monitor color, and perform coin/credit settings.

Press the TEST Button to enter the test mode and to display the following SYSTEM TEST MODE.

```
                SYSTEM TEST MODE

SYSTEM INFORMATION
STORAGE INFORMATION
JVS TEST
MONITOR TEST
SPEAKER TEST
COIN ASSIGNMENTS
CLOCK SETTING
NETWORK SETTING
->EXIT

                SELECT WITH SERVICE BUTTON
                AND PRESS TEST BUTTON
```

SYSTEM TEST MODE screen

### CONTROLS

- Press the SERVICE Button to select menu item.
- Press the TEST Button to execute the selected item.
- Select EXIT and press the TEST Button to return to the game play screen.



**MENU ITEMS**

<b>SYSTEM INFORMATION</b>	Displays system information. (See 3-1.)
<b>STORAGE INFORMATION</b>	Displays information on the game stored in the program. (See 3-2.)
<b>JVS TEST</b>	Displays information on the connected JVS I/O boards. (See 3-3.)
<b>MONITOR TEST</b>	Displays the screen to check the output of the monitor. (See 3-4.)
<b>SPEAKER TEST</b>	Displays the screen to test the output of the speaker. (See 3-5.)
<b>COIN ASSIGNMENTS</b>	Displays the screen to alter the credit settings. (See 3-6.)
<b>CLOCK SETTING</b>	Displays the screen to set the date and time. (See 3-7.)
<b>NETWORK SETTING</b>	Displays the screen to determine network settings or to test the network. (See 3-8.)

## 9-3 SYSTEM INFORMATION

The SYSTEM INFORMATION screen displays system information.

```

                SYSTEM INFORMATION  1/2

KEYCHIP
  KEYCHIP ID      *****
  GAME ID         *****
  MODEL TYPE      **
  REGION          EXP
MAIN BOARD
  MAIN ID         AAV*-*****
  REGION          EXP
  OS VERSION      ****.*.*.*
  MEMORY SIZE     ****MB
  CPU TEMP.       ** [C]
STORAGE DEVICE
  MAIN STORAGE SIZE  ***GB
  SUB STORAGE SIZE  ***GB
GRAPHIC DEVICE
  DEVICE ID       ****:****
  BIOS VERSION    *.*.*.*.*.*

                PRESS TEST BUTTON TO NEXT
    
```

SYSTEM INFORMATION 1/2 screen

### CONTROLS

Press the TEST Button to move to the SYSTEM INFORMATION 2/2 screen.

### MENU ITEMS

<b>KEYCHIP</b>	<b>KEYCHIP ID</b>	The serial number of the key chip
	<b>GAME ID</b>	The game ID of the key chip
	<b>MODEL TYPE</b>	The model type
	<b>REGION</b>	The region setting of the key chip
<b>MAIN BOARD</b>	<b>MAIN ID</b>	The serial number of the game board
	<b>REGION</b>	The region setting of the game board
	<b>OS VERSION</b>	The version of the system program (OS)
	<b>MEMORY SIZE</b>	The onboard memory size
	<b>CPU TEMP.</b>	The temperature of the CPU in Celsius
<b>STORAGE DEVICE</b>	<b>MAIN STORAGE SIZE</b>	The capacity of the main storage
	<b>SUB STORAGE SIZE</b>	The capacity of the sub storage
<b>GRAPHIC DEVICE</b>	<b>DEVICE ID</b>	The graphic device's ID
	<b>BIOS VERSION</b>	The graphic device's software version

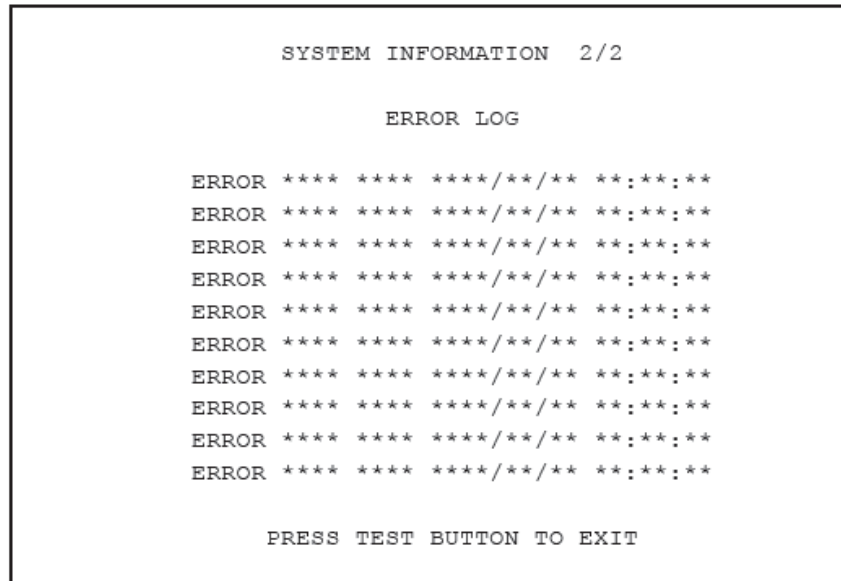

SYSTEM INFORMATION 2/2 screen

**CONTROLS**

Press the TEST Button to return to the SYSTEM TEST MODE screen.

**MENU ITEMS**

<b>ERROR LOG</b>	History list of the error occurred Displays the most recent 10 errors that have occurred in the past. It may not be displayed depending on the version of the installed system program. It may not also be displayed depending on the error.
------------------	---

## 9-4 STORAGE INFORMATION

### STOP IMPORTANT

Do not use FORMAT SUB STORAGE or UNINSTALL without good reason for doing so. Using either of these commands will require the game program to be reinstalled.

The STORAGE INFORMATION screen displays information on the game stored in the Nu. This screen is also used when uninstalling the game stored within the Nu.

Some time may be required to display the file list depending on the timing that TEST MODE was entered. The game program cannot be erased until UNINSTALL is selectable. If the Nu does not contain any game data, "GAME PROGRAM NOT FOUND" screen will be displayed on the item of [Application Title] part.

```
                        STORAGE INFORMATION

                        [ Application Title ] 1/*

                        *****
                        *****
                        *****
                        *****
                        *****
                        *****
                        *****
                        *****
                        *****
                        *****
                        *****
                        *****
                        *****
                        *****
                        *****
                        *****

                        NEXT
                        PREVIOUS
                        FORMAT SUB STORAGE
                        UNINSTALL
                        ->EXIT

                        SELECT WITH SERVICE BUTTON
                        AND PRESS TEST BUTTON
```

STORAGE INFORMATION screen

### CONTROLS

- Press the SERVICE Button to select menu item. Items displayed in grey cannot be selected.
- Press the TEST Button to execute the selected item.
- Select EXIT and press the TEST Button to return to the SYSTEM TEST MODE screen.

## MENU ITEMS

<b>Application Title</b>	Name of installed game program
<b>FILE LIST</b>	Displays the file name for the installed game image. A single page displays up to 10 files. If the files cannot be displayed on a single page, it is possible to switch to and view other pages by selecting NEXT and PREVIOUS.
<b>NEXT</b>	Advances to the next page.
<b>PREVIOUS</b>	Returns to the previous page.
<b>FORMAT SUB STORAGE</b>	Formats the hard disk drive (HDD). Erases all files including the game program currently installed. Select the item and press the TEST Button. YES and NO displays to the right of the item. Press the SERVICE Button to move the underline for selecting items. Move the underline to YES and press the TEST Button to initialize settings and reboot. When the process has completed after rebooting, a message displays that states "DO NOT TURN OFF THE POWER..." When NO is selected, the screen returns to the STORAGE INFORMATION screen without erasing files.
<b>UNINSTALL</b>	The game program currently installed can be erased. Performing this action erases all game programs. It is not possible to select and erase specific files. Select the item and press the TEST Button, YES and NO displays to the right of the item. Press the SERVICE Button to move the underline for selecting items. Move the underline to YES and press the TEST Button to erase the files. If TEST MODE ends, an error is displayed. (See Chapter 4.) When NO is selected, the screen returns to the STORAGE INFORMATION screen without erasing files.

## 9-5 JVS TEST

The JVS TEST screen displays information on the connected JVS I/O boards. The screen display will vary depending on the JVS I/O board that is connected. The following figure is one example.

```

                                JVS TEST

    INPUT TEST
    NODE                        1/1
    ->EXIT

    NAME                        SEGA CORPORATION ; I/O BD JVS ;
                                837-14572 ; Ver1.00 ; 2005/10

    CMD VER                      1.3
    JVS VER                      2.0
    COM VER                      1.0
    SWITCH                      2 PLAYER(S) 14 BIT(S)
    COIN                         2 SLOT(S)
    ANALOG                      8 CH
    ROTARY                      0 CH
    KEYCODE                      0
    SCREEN                      X:0 Y:0 CH:0
    GENERAL IN                  0 BIT(S)
    CARD                        0 SLOT(S)
    HOPPER OUT                 0 CH
    DRIVER OUT                 20CH
    ANALOG OUT                 0 CH
    CHARACTER                  CHARA:0 LINE:0
    BACKUP                     0

                                SELECT WITH SERVICE BUTTON
                                AND PRESS TEST BUTTON
```

JVS TEST screen (when connecting JVS I/O boards)

### CONTROLS

- Press the SERVICE Button to select menu item. Items displayed in grey cannot be selected.
- Press the TEST Button to execute the selected item.
- Select EXIT and press the TEST Button to return to the SYSTEM TEST MODE screen.

**MENU ITEMS**

<b>INPUT TEST</b>	Advances to the JVS I/O board INPUT TEST screen.
<b>NODE</b>	The currently displayed JVS I/O board number and the total number of connected JVS I/O Boards. When there are multiple JVS I/O boards, press the TEST Button while selecting a board to switch between the JVS I/O boards.
<b>NAME</b>	Name of the connected JVS I/O board, etc.
<b>CMD VER</b>	Command format version
<b>JVS VER</b>	JV standard (JVS) version
<b>COM VER</b>	Communication version
<b>SWITCH</b>	Number of players and number of 1P switches
<b>COIN</b>	Number of coin slots
<b>ANALOG</b>	Number of analog channels
<b>ROTARY</b>	Number of rotary encoders
<b>KEYCODE</b>	Key code input active/inactive
<b>SCREEN</b>	Screen position input (X axis, Y axis, number of channels)
<b>GENERAL IN</b>	Number of standard switches
<b>CARD</b>	Number of card slots
<b>HOPPER OUT</b>	Number of hoppers
<b>DRIVER OUT</b>	Number of standard output drivers
<b>ANALOG OUT</b>	Number of analog output channels
<b>CHARACTER</b>	Number of characters/lines displayed
<b>BACKUP</b>	Backup present/absent

The following displays when there are no JVS I/O boards connected.

```

JVS TEST

NO JVS NODE

->EXIT

SELECT WITH SERVICE BUTTON
AND PRESS TEST BUTTON

```

JVS TEST screen (when not connecting JVS I/O boards)

## JVS INPUT TEST

Use the JVS INPUT TEST to test the JVS I/O board input. The hexadecimal input information from the JVS I/O board will be displayed in real time. The screen display will vary depending on the JVS I/O board that is connected. The following figure is one example.

JVS TEST INPUT TEST	
NODE	*/*
SYSTEM	00
PLAYER 1	0000
PLAYER 2	0000
COIN 1	0000
COIN 2	0000
ANALOG 0	0000
ANALOG 1	0000
ANALOG 2	0000
ANALOG 3	0000
ANALOG 4	0000
ANALOG 5	0000
ANALOG 6	0000
ANALOG 7	0000
ANALOG 8	0000

PRESS TEST BUTTON AND  
SERVICE BUTTON TO EXIT

JVS INPUT TEST screen

### CONTROLS

Press the SERVICE and TEST Buttons simultaneously to return to the JVS TEST screen.

### MENU ITEMS

<b>SYSTEM</b>	System switch input data
<b>PLAYER</b>	Player number and player switch input data
<b>COIN</b>	Slot number and coin input data
<b>ANALOG</b>	Channel number and analog input data



## 9-6 MONITOR TEST

Use MONITOR TEST to check the output of the monitor.

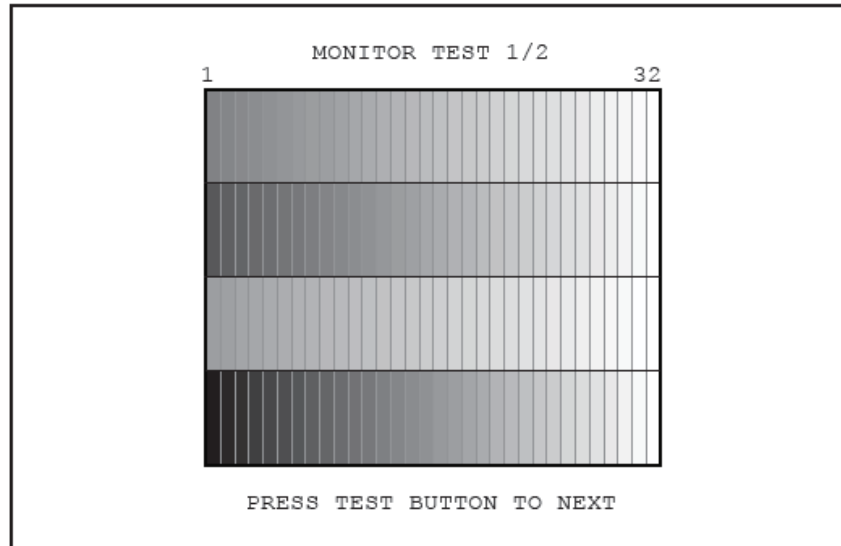

MONITOR TEST 1/2 screen

### CONTROLS

- Displays a gradation of red, green, blue and white from the top in that order. "1" is the darkest, and moving towards "32" incrementally becomes lighter. Ensure that each color displays correctly.
- Press the TEST Button to move to the MONITOR TEST 2/2 screen.

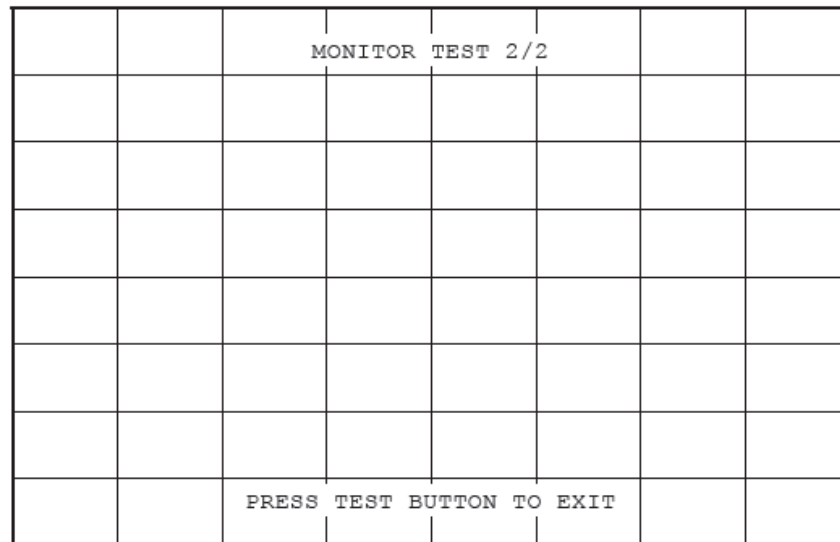

MONITOR TEST 2/2 screen

### CONTROLS

- A grid displays on the entire screen. Ensure there are no distortions on the display.
- Press the TEST Button to return to the SYSTEM TEST MODE screen.

## 9-7 SPEAKER TEST

Use SPEAKER TEST to check the output of each speaker.

```
                SPEAKER TEST

FRONT LEFT SPEAKER    OFF
FRONT RIGHT SPEAKER   OFF
REAR LEFT SPEAKER     OFF
REAR RIGHT SPEAKER    OFF
CENTER SPEAKER        OFF
WOOFER SPEAKER        OFF

->EXIT

        SELECT WITH SERVICE BUTTON
        AND PRESS TEST BUTTON
```

SPEAKER TEST screen

### CONTROLS

- Press the SERVICE Button to select each speaker.
- Press the TEST Button to toggle between ON and OFF to the right of the selected speaker. When set to ON, a test sound will be emitted from that speaker. It is possible to set multiple speakers to emit the test sound at the same time. Depending on the cabinet used, some items will be displayed but no sound will be emitted.
- Select EXIT and press the TEST Button to return to the SYSTEM TEST MODE screen.

## 9-8 COIN ASSIGNMENTS

Sets the coin/credit (charge).

To enable the changed settings, return to the SYSTEM TEST MODE screen and exit. After exiting the screen, the changes to the settings are saved and the changes are then enabled. If the power is turned off without exiting, the changed settings are not saved.

There are designated coin/credit settings depending on the game program. Refer to the manual for each game for details.

```
COIN ASSIGNMENTS

COIN CHUTE TYPE      COMMON
SERVICE TYPE        COMMON
COIN CHUTE #1 COIN TO CREDIT RATE
  1 COIN(S) COUNT AS 1 CREDIT(S)
COIN CHUTE #2 COIN TO CREDIT RATE
  1 COIN(S) COUNT AS 1 CREDIT(S)
DETAIL SETTING
GAME COST SETTING
->EXIT

SELECT WITH SERVICE BUTTON
AND PRESS TEST BUTTON
```

COIN ASSIGNMENTS screen (COIN CHUTE TYPE: COMMON)

### CONTROLS

- Press the SERVICE Button to select menu item.
- Press the TEST Button to change settings for the selected item, or proceed to the selected settings screen.
- Select EXIT and press the TEST Button to return to the SYSTEM TEST MODE screen.

**MENU ITEMS**

<b>COIN CHUTE TYPE</b>	Specify according to the cabinet coin chute specifications.	
	<b>COMMON</b>	This is for cabinets that use a coin chute shared by multiple players. Coins inserted by each player are handled as shared credit. Up to 2 coin chutes (#1, #2) can be used, and it is possible to set a coin chute multiplier for #1 and #2 separately.
	<b>INDIVIDUAL</b>	This is for cabinets set up for each coin chute for multiple players. Coins inserted by each player are handled as credit for each individual player. The setting for the coin chute multiplier is common to each coin chute.
<b>SERVICE TYPE</b>	Sets the operation for when pressing the SERVICE Button, when there are multiple SERVICE buttons.	
	<b>COMMON</b>	All players receive service credit no matter which SERVICE Button is pressed.
	<b>INDIVIDUAL</b>	The player that corresponds to the SERVICE Button being pressed only receives credit.
<b>COIN/CREDIT SETTING</b>	Sets the amount of credit associated with inserted coins. "X COIN(S) COUNT AS Y CREDIT(S)" indicates that when X coins are inserted, Y credits are received. Setting to FREE PLAY allows you to play the game without credits. When COIN CHUTE TYPE is set to COMMON, the coin chute #2 setting is limited to a certain extent more than the coin chute #1 setting.	
<b>DETAIL SETTING</b>	Advances to a screen for more detailed settings than COIN/CREDIT SETTING to set the amount of credit associated with inserted coins. (See 3-6-1.) When using DETAIL SETTINGS, settings for the COIN/CREDIT SETTING are disabled.	
<b>GAME COST SETTING</b>	Advances to a screen where settings can be specified such as for the required quantity of credits to begin a game. (See 3-6-2.) The range for setting values, the screen display and other similar items are different depending on the game program. Refer to the manual for each game for details.	

**COIN/CREDIT SETTING TABLE 1-1 (COIN CHUTE TYPE: COMMON)**

When operating coin chute #1, coin chute #2 is linked to the operation and changes accordingly.

COIN CHUTE #1 COIN TO CREDIT RATE
1 coin counts as 1 credit
2 coins count as 1 credit
3 coins count as 1 credit
4 coins count as 1 credit
5 coins count as 1 credit
1 coin counts as 2 credits
1 coin counts as 3 credits
1 coin counts as 4 credits
1 coin counts as 5 credits
Free play (no coins required)

COIN CHUTE #2 COIN TO CREDIT RATE
1 coin counts as 1 credit
2 coins count as 1 credit
3 coins count as 1 credit
4 coins count as 1 credit
5 coins count as 1 credit
1 coin counts as 2 credits
1 coin counts as 3 credits
1 coin counts as 4 credits
1 coin counts as 5 credits
Free play (no coins required)

**COIN/CREDIT SETTING TABLE 1-2 (COIN CHUTE TYPE: COMMON)**

When operating coin chute #2, coin chute #1 does not change.

COIN CHUTE #1 COIN TO CREDIT RATE
Same as table 1-1 above.

COIN CHUTE #2 COIN TO CREDIT RATE
1 coin counts as 1 credit
1 coin counts as 2 credits
1 coin counts as 3 credits
1 coin counts as 4 credits
1 coin counts as 5 credits

**COIN/CREDIT SETTING TABLE 2 (COIN CHUTE TYPE: INDIVIDUAL)**

COIN CHUTE #1 COIN TO CREDIT RATE
1 coin counts as 1 credit
2 coins count as 1 credit
3 coins count as 1 credit
4 coins count as 1 credit
5 coins count as 1 credit
1 coin counts as 2 credits
1 coin counts as 3 credits
1 coin counts as 4 credits
1 coin counts as 5 credits
Free play (no coins required)

COIN CHUTE #2 COIN TO CREDIT RATE
When set to INDIVIDUAL, coin chute #1 and coin chute #2 have the same coin/credit setting.

```

          COIN ASSIGNMENTS
          DETAIL SETTING

COIN CHUTE #1 MULTIPLIER
  1 COIN COUNT AS  1 COIN(S)
COIN CHUTE #2 MULTIPLIER
  1 COIN COUNT AS  1 COIN(S)
BONUS ADDER          NO BONUS ADDER

COIN TO CREDIT      1 COIN(S) 1 CREDIT
->EXIT

          COIN CHUTE #1 OPERATION
COIN      1  2  3  4  5  6  7  8  9
CREDIT    1  2  3  4  5  6  7  8  9

          COIN CHUTE #2 OPERATION
COIN      1  2  3  4  5  6  7  8  9
CREDIT    1  2  3  4  5  6  7  8  9

          SELECT WITH SERVICE BUTTON
          AND PRESS TEST BUTTON
    
```

DETAIL SETTING screen (COIN CHUTE TYPE: COMMON)

**CONTROLS**

- Press the SERVICE Button to select menu item.
- Press the TEST Button to change the selected item's setting.
- Select EXIT and press the TEST Button to return to the COIN ASSIGNMENTS screen.

**MENU ITEMS**

<b>COIN CHUTE #* MULTIPLIER</b>	Sets how many coins to count for a single inserted coin. "1 COIN COUNT AS X COIN(S)" [1 coin inserted counts as X coin(s)] indicates that 1 coin is converted into X number of coins. When COIN CHUTE TYPE is set to COMMON, coin chute #1 and #2 can be set separately.
<b>BONUS ADDER</b>	Sets how many coins converted at COIN CHUTE #* MULTIPLIER are required to give 1 bonus coin. When COIN CHUTE TYPE is set to COMMON, the sum of the number of coins for coin chute #1 and #2 is used for the calculation. "X COINS GIVE 1 EXTRA COIN" (X coins inserted successively award 1 bonus coin) indicates that 1 bonus coin is given for X amount of coins. The NO BONUS ADDER setting means that no bonus coin is given.
<b>COIN TO CREDIT</b>	"X COIN(S) 1 CREDIT" [X coin(s) give 1 credit] indicates that X number of coins is converted to 1 credit.

**DETAIL SETTING 1 (COIN CHUTE TYPE: COMMON)**

COIN CHUTE #1 MULTIPLIER
1 coin inserted counts as 1 coin
1 coin inserted counts as 2 coins
1 coin inserted counts as 3 coins
1 coin inserted counts as 4 coins
1 coin inserted counts as 5 coins
1 coin inserted counts as 6 coins
1 coin inserted counts as 7 coins
1 coin inserted counts as 8 coins
1 coin inserted counts as 9 coins

COIN CHUTE #2 MULTIPLIER
1 coin inserted counts as 1 coin
1 coin inserted counts as 2 coins
1 coin inserted counts as 3 coins
1 coin inserted counts as 4 coins
1 coin inserted counts as 5 coins
1 coin inserted counts as 6 coins
1 coin inserted counts as 7 coins
1 coin inserted counts as 8 coins
1 coin inserted counts as 9 coins

**DETAIL SETTING 2 (COIN CHUTE TYPE: INDIVIDUAL)**

COIN CHUTE #1 MULTIPLIER
1 coin inserted counts as 1 coin
1 coin inserted counts as 2 coins
1 coin inserted counts as 3 coins
1 coin inserted counts as 4 coins
1 coin inserted counts as 5 coins
1 coin inserted counts as 6 coins
1 coin inserted counts as 7 coins
1 coin inserted counts as 8 coins
1 coin inserted counts as 9 coins

COIN CHUTE #2 MULTIPLIER
When set to INDIVIDUAL, coin chute #1 and coin chute #2 have the same coin/credit setting.

**DETAIL SETTING 3 (BONUS ADDER)**

No bonus coin given
2 coins inserted successively award 1 bonus coin
3 coins inserted successively award 1 bonus coin
4 coins inserted successively award 1 bonus coin
5 coins inserted successively award 1 bonus coin
6 coins inserted successively award 1 bonus coin
7 coins inserted successively award 1 bonus coin
8 coins inserted successively award 1 bonus coin
9 coins inserted successively award 1 bonus coin

**DETAIL SETTING 4 (COIN TO CREDIT)**

1 coin gives 1 credit
2 coins give 1 credit
3 coins give 1 credit
4 coins give 1 credit
5 coins give 1 credit
6 coins give 1 credit
7 coins give 1 credit
8 coins give 1 credit
9 coins give 1 credit

## GAME COST SETTINGS

The range for setting values, the screen display and other similar items are different depending on the game program. The following figure is one example.

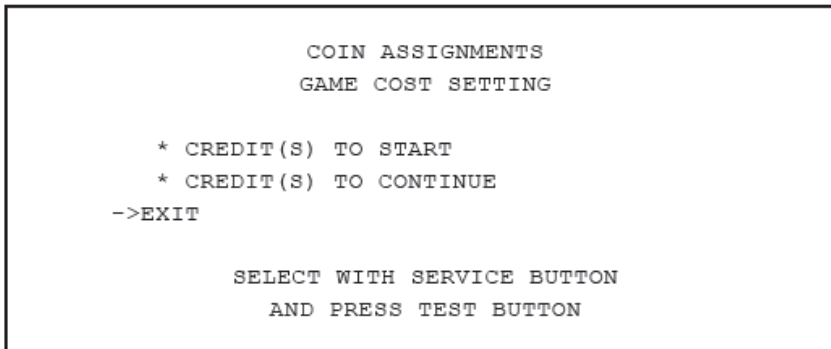

GAME COST SETTING screen

### CONTROLS

- Press the SERVICE Button to select menu item.
- Press the TEST Button to change the selected item's setting.
- Select EXIT and press the TEST Button to return to the COIN ASSIGNMENTS screen.

### MENU ITEMS

* credit(s) to start	Sets the number of credits required to start the game.
* credit(s) to continue	Sets the number of credits required to continue the game.



## 9-9 CLOCK SETTING

Use CLOCK SETTING to set the date and time. Displays the current date and time. This can also be changed. Ensure the date and time is set correctly because it is used for error logs, game test mode BOOKKEEPING and other such features.

Be aware that changing the time setting may make it not possible to play ALL.Net compatible games.

ALL.Net compatible games are time synchronized by ALL.Net authentication when the game program is started, and the time setting is overwritten. Set up a network environment that can connect to an ALL.Net server.

```
CLOCK SETTING

CLOCK
  ****/**/** (****) **: **: **

->EXIT

SELECT WITH SERVICE BUTTON
AND PRESS TEST BUTTON
```

CLOCK SETTING screen

### CONTROLS

- Press the SERVICE Button to select menu item.
- Select EXIT and press the TEST Button to return to the SYSTEM TEST MODE screen.

### MENU ITEMS

<b>CLOCK</b>	Displays the current date and time. Select the item and press the TEST button to change the date and time.
--------------	---

## How to set the time

- 1 Press the SERVICE Button to move through the selections of CANCEL→Year→Month→Day→Hour→Minutes→Seconds→SET→CANCEL→...in that order. Press the TEST Button to increase the value of the selected item. Also, press and hold the TEST Button to increase the value. Select CANCEL and then press the TEST button to return to the CLOCK SETTING screen.

```
CLOCK SETTING

CLOCK
****/**/** (***) **:**:** SET CANCEL

->EXIT

SELECT WITH SERVICE BUTTON
AND PRESS TEST BUTTON
```

CLOCK SETTING screen (while changing)

- 2 Select SET and then select EXIT, and press the TEST Button. A confirmation message displays.

```
CLOCK SETTING

CLOCK
****/**/** (***) **:**:**

DO YOU WISH TO PROCEED?

->EXIT      NO (CANCEL) YES (CHANGE)

SELECT WITH SERVICE BUTTON
AND PRESS TEST BUTTON
```

CLOCK SETTING screen (confirmation message)

- 3 Press the SERVICE Button and select from NO (CANCEL) or YES (CHANGE). When YES (CHANGE) is selected and the TEST Button is pressed, the changes are saved and the screen returns to the SYSTEM TEST MODE screen. When NO (CANCEL) is selected and the TEST Button is pressed, the screen returns to the SYSTEM TEST MODE screen without saving the changes.

## 9-10 NETWORK SETTING

Use NETWORK SETTING to determine network settings or to test the network.  
There is no need to alter these settings for a game that does not use a network.

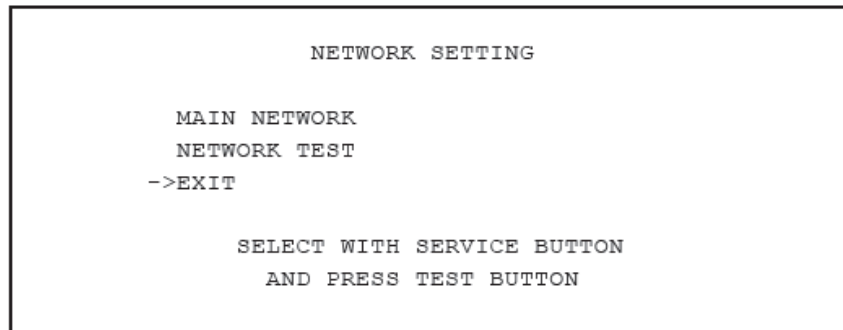

NETWORK SETTING (Setting Menu) screen

### CONTROLS

- Press the SERVICE Button to select menu item.
- Press the TEST Button to execute the selected item.
- Select EXIT and press the TEST Button to return to the SYSTEM TEST MODE screen.

### MENU ITEMS

MAIN NETWORK	Performs a network setting.
NETWORK TEST	Performs a network test.

The screen display will vary depending on the game program. The following figure is one example.

```

NETWORK SETTING
MAIN NETWORK

MAC ADDRESS      **--**--**--**--**--**
DHCP             ****
IP ADDRESS
  ***.***.***.***
SUBNET MASK
  ***.***.***.***
GATEWAY
  ***.***.***.***
PRIMARY DNS
  ***.***.***.***
SECONDARY DNS
  ***.***.***.***
->EXIT

SELECT WITH SERVICE BUTTON
AND PRESS TEST BUTTON
    
```

MAIN NETWORK screen

**CONTROLS**

- Press the SERVICE Button to select menu item.
- Press the TEST button to display the underline for SET and CANCEL to the right of the character string under the selected item.

```

->SUBNET MASK
  ***.***.***.*** SET CANCEL
GATEWAY
  ***.***.***.***
PRIMARY DNS
  ***.***.***.***
SECONDARY DNS
  ***.***.***.***
EXIT
    
```

MAIN NETWORK screen (while changing)

- With the underline displayed, press the SERVICE button to move the underline.
- Pressing the TEST Button increases the value at the location where the underline is displayed.
- When saving the value for the changed setting, move the underline to SET and press the TEST Button. If you do not want to save the changes, move the underline to CANCEL and press the TEST Button.
- When the underline is selecting either SET or CANCEL and the TEST Button is pressed, SET, CANCEL and the underline disappear.
- Select EXIT and press the TEST Button to return to the NETWORK SETTING (Setting Menu) screen.

## MENU ITEMS

<b>MAC ADDRESS</b>	The individual ID number assigned to each device using the Ethernet.	
<b>DHCP</b>	Set automatic acquisition of network settings.	
	<b>ENABLE</b>	Acquire network settings automatically.
	<b>DISABLE</b>	Input network settings manually.
<b>IP ADDRESS</b>	A setting required for the network. See the manual supplied with each game software for the correct setting. After setting the numbers, select SET and press the TEST Button to save the setting. When DHCP is set to ENABLE, this item cannot be selected.	
<b>SUBNET MASK</b>		
<b>GATEWAY</b>		
<b>PRIMARY DNS</b>		
<b>SECONDARY DNS</b>		

## NETWORK TEST

This section is for performing operation tests for communication connectivity. No operation is possible until the test results are displayed.

The screen display will vary depending on the game program. The following figure is one example.

```
NETWORK SETTING
NETWORK TEST

LINKUP ---- *****
LOOPBACK -- *****
DHCP ----- *****
GATEWAY --- *****
ROUTER ---- *****
HOPS ----- *
SERVER ---- *****

PRESS TEST BUTTON TO EXIT
```

NETWORK TEST screen

### CONTROLS

Press the TEST Button to return to the NETWORK SETTING (Setting Menu) screen.

### MENU ITEMS

<b>LINKUP</b>	LAN cable connection status.
<b>LOOPBACK</b>	The Nu network function operation status.
<b>DHCP</b>	Status of communication settings acquisition when DHCP is set to ENABLE.
<b>GATEWAY</b>	Status of connection with title router, etc.
<b>ROUTER</b>	Status of connection with ALL.Net router.
<b>HOPS</b>	Number of router connections to ALL.Net router.
<b>SERVER</b>	Status of connection with ALL.Net server.

The status of determining items is as listed in the table below:

<b>CHECK</b>	Indicates that the item is currently being checked.
<b>GOOD</b>	Indicates that the item is functioning normally.
<b>BAD</b>	Indicates that the item is not functioning normally. (Damaged, incorrect settings, etc.)
<b>N/A</b>	Indicates that the item has not been checked. (Prerequisites have not been met, etc.)

## 9-11 GAME TEST MENU

### GAME TEST MENU

Press test button to enter GAME TEST MENU screen.

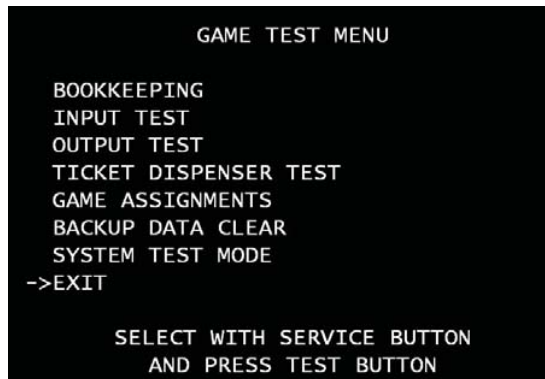

#### ■Control

- Use the SERVICE Button to move the cursor to the desired test item.
- Press the TEST Button to confirm selection of the item.
- Select EXIT and press the TEST Button to return to the SYSTEM TEST MODE screen.

#### ■Menu Item

BOOKKEEPING	Displays all recorded game data.
INPUT TEST	Tests each input device used for the game.
OUTPUT TEST	Tests each output device used for the game.
TICKET DISPENSER TEST	Tests vending ticket machines.
GAME ASSIGNMENTS	Adjusts all game settings
BACKUP DATA CLEAR	Erases all types of game records.
SYSTEM TEST MODE	Enter SYSTEM TEST MODE

## 9-12 BOOKKEEPING

### BOOKKEEPING(1/4)

Each game record can be viewed.

```
BOOKKEEPING 1/4

COIN1          0
COIN2          0
TOTAL COINS    0

COIN CREDITS   0
SERVICE CREDITS 0
TOTAL CREDITS  0

PRESS TEST BUTTON TO NEXT
```

#### ■Control

- Press the TEST Button to move to BOOKKEEPING 2/4 screen.

#### ■Menu Item

COIN1	Number of coins inserted in coin chute 1.
COIN2	Number of coins inserted in coin chute 2.
TOTAL COINS	Total Number of coins inserted in coin chute.
COIN CREDITS	Number of credits for coins inserted.
SERVICE CREDITS	Number of credits entered with the SERVICE Button.
TOTAL CREDITS	Total number of all credits.



BOOKKEEPING(2/4)\*\*Video Redemption

\*It has difference text between Video Redemption mode and Amusement only mode for Bookkeeping 2/4.

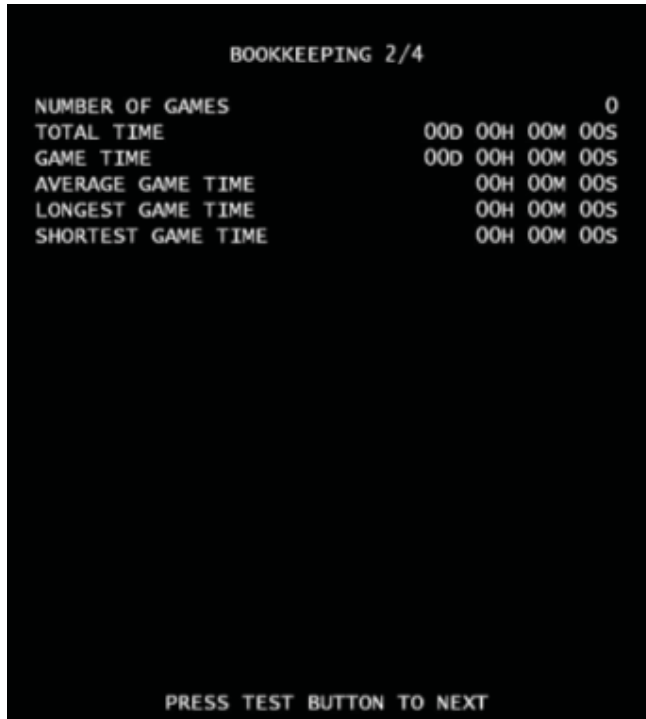

■ Control

- Press the TEST Button to move to BOOKKEEPING 2/4 screen.

■ Menu Item

NUMBER OF GAMES	Total number of games played by a player.
TOTAL TIME	Amount of time the cabinet has been in operation.
GAME TIME	Amount of time the game has been played.
AVERAGE GAME TIME	Average control time for one game.
LONGEST GAME TIME	Longest play time for one game.
SHORTEST GAME TIME	Shortest play time for one game.

BOOKKEEPING(2/4) \*Amusement only mode

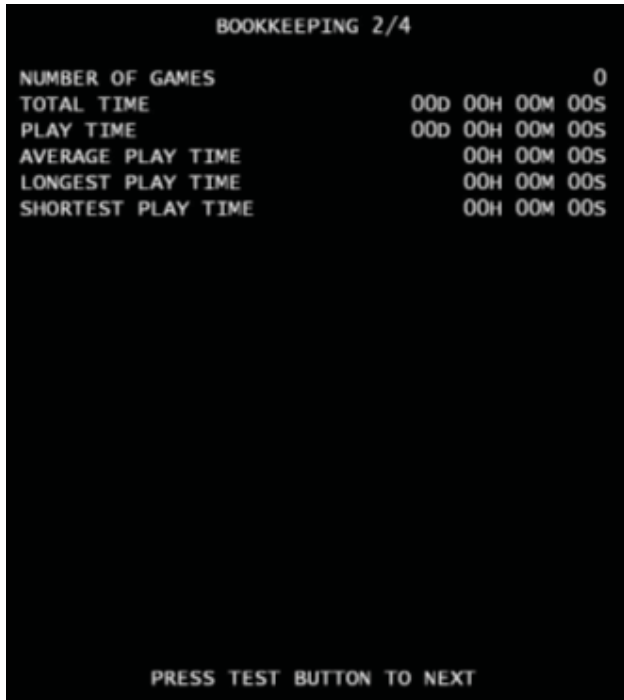

- Control
  - Press the TEST Button to move to BOOKKEEPING 3/4 screen.

■ Menu Item

NUMBER OF GAMES	Total number of games played by a player.
TOTAL TIME	Amount of time the cabinet has been in operation.
PLAY TIME	Amount of time the game has been played.
AVERAGE PLAY TIME	Average play time for one game..
LONGEST PLAY TIME	Longest play time for one game.
SHORTEST PLAY TIME	Shortest play time for one game.

## BOOKKEEPING(3/4)

\*It is for Video Redemption mode only. On the Amusement only mode, text color changes to gray.

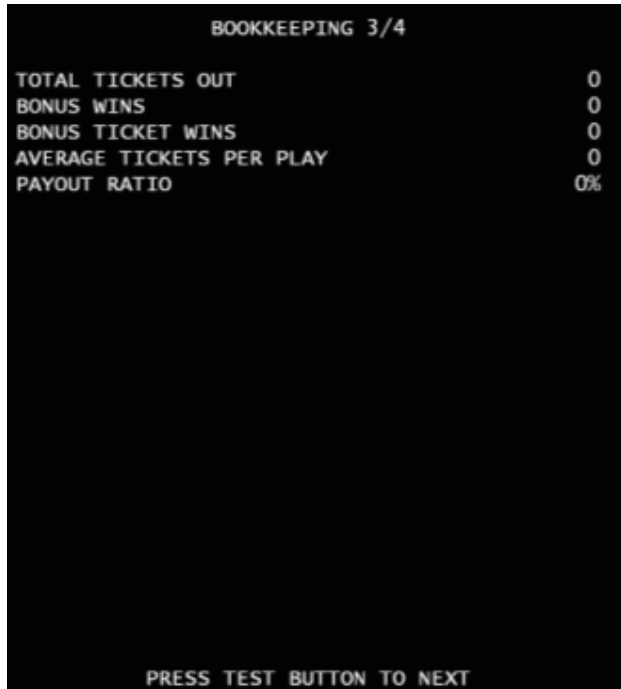

### ■ Control

- Press the TEST Button to move to BOOKKEEPING 4/4 screen.

### ■ Menu Item

TOTAL TICKET OUT	Total number of paid tickets..
BONUS WINS	Amount of time of Super Bonus
BONUS TICKET WINS	Amount of tickets paid by Super Bonus
AVERAGE TICKETS PER PLAY	Average tickets paid number for one game.
PAYOUT RATIO	Ticket Payout Rate by income. If the Payout Rate is over than 100, it will display "100%."

## BOOKKEEPING(4/4)

```
BOOKKEEPING 4/4
TIME HISTOGRAM
0M00S ~ 0M29S      0
0M30S ~ 0M59S      0
1M00S ~ 1M29S      0
1M30S ~ 1M59S      0
2M00S ~ 2M29S      0
2M30S ~ 2M59S      0
3M00S ~ 3M29S      0
3M30S ~ 3M59S      0
4M00S ~ 4M29S      0
4M30S ~ 4M59S      0
OVER 5M00S         0
PRESS TEST BUTTON TO EXIT
```

### ■Control

- Press the TEST Button to return to GAME TEST MODE screen.

### ■Menu Item

Play time will be recorded into different lines by 30 seconds intervals.  
All play times over 5 minutes are written into the line OVER 5M00S.

## 9-13 INPUT TEST

### INPUT TEST

Look up the status of each input devices.



#### ■Control

- Press TEST button and SERVICE button at the same time to return to GAME TEST MODE screen.
- When the corresponding menu items displays from "OFF" to "ON" or corresponding data reacts to the action, the device is then functional.

#### ■Menu Item

TEST	Press TEST button, this item will display "ON", release the button, the item will display "OFF".
SERVICE	Press SERVICE button, this item will display "ON", release the button, the item will display "OFF".
RELEASE BUTTON	Press ticket release button inside ticket vending box, this item will display "ON", release the button, the item will display "OFF".
UP	Press UP side of the direction pad, this item will display "ON", release the button, the item will display "OFF".
DOWN	Press Down side of the direction pad, this item will display "ON", release the button, the item will display "OFF".
LEFT	Press Left side of the direction pad, this item will display "ON", release the button, the item will display "OFF".
RIGHT	Press Right side of the direction pad, this item will display "ON", release the button, the item will display "OFF".
START/DASH	Press the START/DASH button, the item will display "ON", release the button, the item will display "OFF".

## 9-14 OUTPUT TEST

### OUTPUT TEST

Test all the output devices utilized in game. Please test all the output devices in regular term.

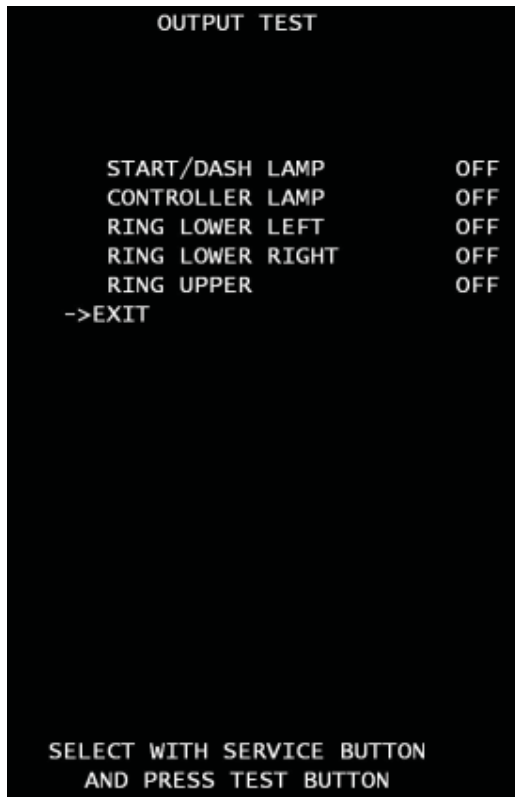

#### ■Control

- Use the SERVICE Button to move the cursor to the desired test item.
- Press the TEST Button to confirm selection of the item.
- Select EXIT and press the TEST Button to return to GAME TEST MODE screen.

#### ■Menu Item

START/DASH LAMP	START/DASH button to light the lamp.
CONTROLLER LAMP	The lamp of the direction button is on. Every time the test button is pressed, the color will display in the order RED-GREEN-BLUE-MAGENDA-CYAN-YELLOW-WHITE-OFF. Default is "OFF".
RING LOWER LEFT	The lamp at the left ring of lower cabinet is on. Every time the test button is pressed, the color will display in the order RED-GREEN-BLUE-MAGENDA-CYAN-YELLOW-WHITE-OFF. Default is "OFF".
RING LOWER RIGHT	The lamp at the right ring of lower cabinet is on. Every time the test button is pressed, the color will display in the order RED-GREEN-BLUE-MAGENDA-CYAN-YELLOW-WHITE-OFF. Default is "OFF".
RING UPPER	The lamp at both sides of the screen is on. Every time the test button is pressed, the color will display in the order RED-GREEN-BLUE-MAGENDA-CYAN-YELLOW-WHITE-OFF. Default is "OFF".

## 9-15 TICKET TEST

### TICKET DISPENSER TEST

Test all the ticket vending devices utilized in game.

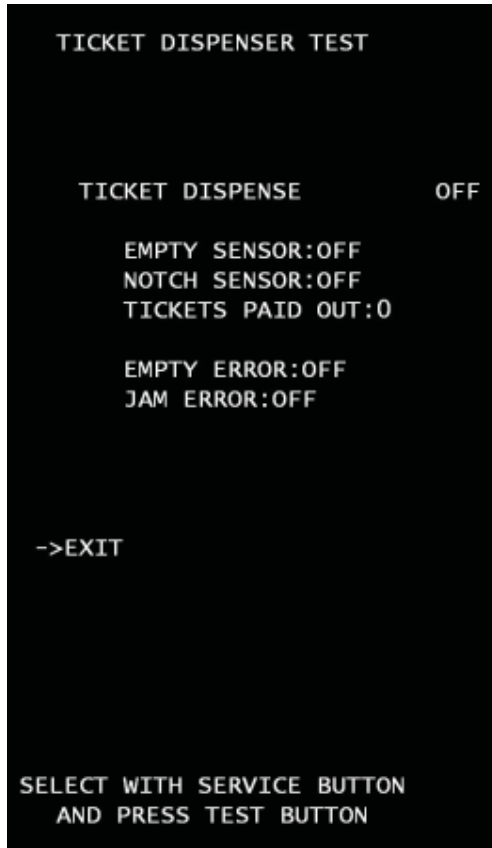

#### ■Control

- Use the SERVICE Button to move the cursor to the desired test item.
- Press the TEST Button to confirm selection of the item.
- Select EXIT and press the TEST Button to return to GAME TEST MODE screen.

#### ■Menu Item

TICKET DISPENSE	Press TEST button, this item will display "ON" and Ticket vending works. The test button is pressed again, the item will display "OFF" and Ticket vending stops.
EMPTY SENSOR	The status of ticket empty sensor. The item will display "OFF" if ticket box is enough to play to vend tickets. If it's not, the sensor will work and the item will display "ON".
NOTCH SENSOR	The status of notch sensor for the ticket. The item will display "ON" when sensor find the notch of ticket.
TICKET PAID PUT	Amount of tickets paid during this mode.
EMPTY ERROR	The current status of ticket empty error. If the status is error, The item will display "ON"
JAM ERROR	The current status of ticket jam error. If the status is error, The item will display "ON"

**If Error status is "ON", please respond for each error, and then press Ticket Release Switch to back normal.**

## 9-16 GAME ASSIGNMENTS

### GAME ASSIGNMENTS

Game setting configuration. The gray color means not select. It depends on each mode.

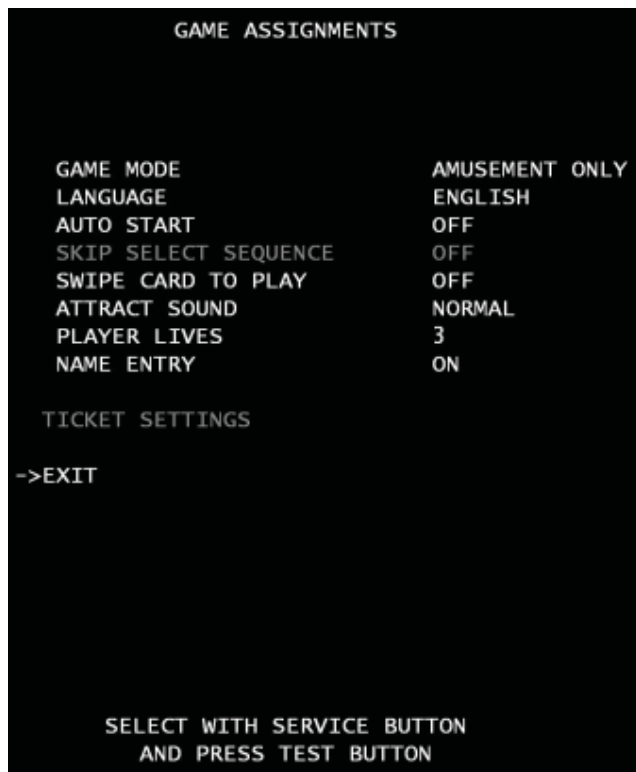

#### ■Control

- Use the SERVICE Button to move the cursor to the desired test item.
- Press the TEST Button to confirm selection of the item.
- Select EXIT and press the TEST Button to return to the GAME TEST MODE screen.

#### ■Menu Item

GAME MODE	Set "Ticket Redemption" or "Amusement Only" (no tickets). "TICKET REDEMPTION" is set by default.
LANGUAGE	Set a language. 6 options ENGLISH – FRENCH – ITALIAN – SPANISH – TURKISH - RUSSI to choose from. ENGLISH is set by default.
AUTO START	Can set automatic start. If the option is set to "ON", The game will start without pressing start button when credits is available to play. If the option is set to "OFF", The game will wait to start until pressing start button as usual. "OFF" is set by default.
*SKIP SELECT SEQUENCE	Set skip a character select sequence. If the option is set to "ON", it will skip and automatically select players character with random. If the option is set to "OFF", A character select sequence appears.. "OFF" is set by default *Ticket Redemption mode only available.
SWIP CARD TO PLAY	Change the text at the screen bottom. If the setting is set to "ON", "SWIPE CARD TO PLAY" will be shown at the screen bottom. If the setting is set to "OFF", "INSERT COIN(S)"/"INSERT MORE COIN(S)" will be shown at the screen bottom as usual. "OFF" is set by default.
ATTRACT SOUND	Set the volume of attraction movie. 5 options NORMAL- OFF - 1/4 – 1/2 – 3/4 to choose from. "NORMAL" is set by default.
**PLAYER LIVES	Sets the number of monkeys (lives). 6 options 3 – 4- 5- UNLIMITED – 1 – 2 to choose from. 3 is set by default.** Amusement only mode is available. 1 is fixed on video redemption mode.
**NAME ENTRY	Set name entry sequence. If the option is set to "ON", high scored player can entry his name to ranking . If the option is set to "OFF", it will not ***Amusement only available.
*TICKET SETTING	Move to TICKET SETTING MODE *Ticket Redemption mode only available.



□ Changing game mode.

When game mode changes, below screen will be shown.

■ Control

\*Press SERVICE button to select menu item.

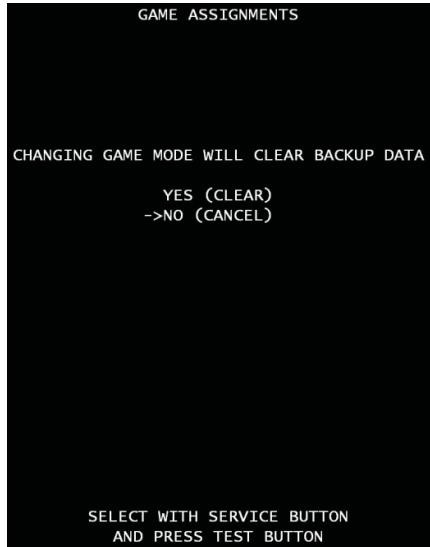

\*Select “YES (CLEAR)” and press TEST button to clear all backup data. When “COMPLETED” is displayed, press TEST button again and return to GAME TEST MODE screen.

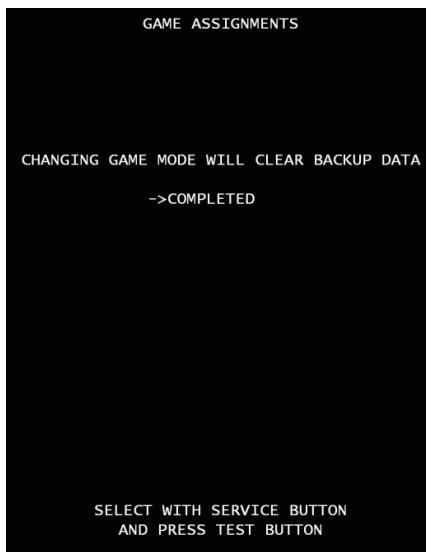

\*Select “NO (CANCEL)” and press TEST button, no action will be executed and return to GAME ASSIGNMENTS screen directly.

## 9-17 TICKET SETTINGS

### ATTENTION!!!

We recommend BACKUP DATA CLEAR when the Ticket payout setting and setting that related to Payout rate were changed because some time cause confusion of BOOKKEEPING data.

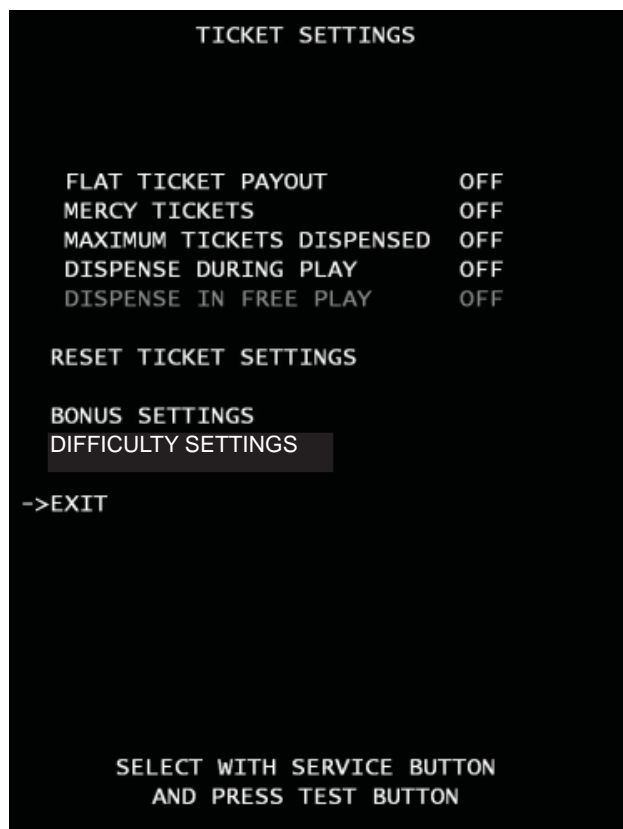

#### ■Control

- Use the SERVICE Button to move the cursor to the desired test item.
- Press the TEST Button to confirm selection of the item.
- Select EXIT and press the TEST Button to return to the GAME ASSIGNMENT screen.

#### ■Menu Item

FLAT TICKET PAYOUT	Each player will receive the same amount of tickets, Regardless of points scored. Every time the test button is pressed, the color will display in the order +1 from 1 to 10. OFF is set by default.
MERCY TICKET	Player will receive ticket(s) regardless of points scored. Every time the test button is pressed, the number will display in the order +1 from 1 to 5. OFF is set by default.
MAXIMUM TICKETS DISPENSED	Sets the maximum number of tickets through the dispenser for each game. Any value in excess of the set value must be paid manually by attendant.. Every time the test button is pressed, the number will display in the order +100 from 100 to 1000. OFF is set by default.
DISPENSE DURING PLAY	If set to ON, tickets will be paid during game play. Default value is OFF, all tickets will be paid at the end of the game. OFF is set by default.
DISPENSE IN FREE PLAY*	Enables/disables ticket payout in FREE PLAY. *This setting is used only in "FREE PLAY" mode.
RESET TICKET SETTING	Set all of the TICKET SETTINGS back to the factory default values.
BONUS SETTING	Go to Bonus Settings
DIFFICULTY SETTING	Go to Difficulty Settings

## 9-18 BONUS SETTINGS

Ticket bonus setting.

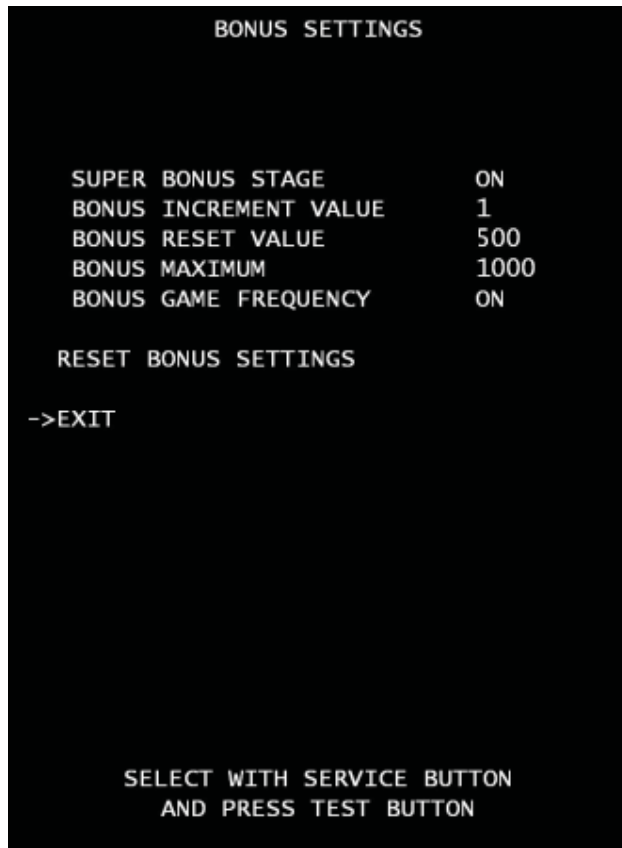

### ■Control

- Use the SERVICE Button to move the cursor to the desired test item.
- Press the TEST Button to confirm selection of the item.
- Select EXIT and press the TEST Button to return to the TICKET SETTING screen.

### ■Menu Item

SUPER BONUS STAGE	If set to ON, the Bonus stage appears after a character pass the goal. ON is set by default.
BONUS INCREMENT VALUE	Amount of points will increase for every game played. If set to OFF, non progressive. 2 option "1" and "OFF" to choose from. 1 is set by default.
BONUS RESET VALUE	The beginning/reset value of the Bonus amount. Every time the test button is pressed, the number will display in the order +50 from 100 to 1000. Under 100, you can set 25, 50, 75. 500 is set by default.
BONUS MAXIMUM	Sets the number of maximum progressive value. *Please set "BONUS RESET VALUE" up first. The maximum number must be more than "BONUS RESET VALUE" amount. Every time the test button is pressed, the number will display in the order +50 from 100 to 1000. Under 100, you can set 25, 50, 75. 1000 is set by default.
BONUS GAME FREQUENCY	Use random frequency in Super Bonus game. ON is set by default.
RESET BONUS SETTING	Set all of the BONUS SETTINGS back to the factory default values.

## 9-19 DIFFICULTY SETTINGS

### DIFFICULTY SETTING

Ticket OUTPUT setting.



#### ■Control

- Use the SERVICE Button to move the cursor to the desired test item.
- Press the TEST Button to confirm selection of the item.
- Select EXIT and press the TEST Button to return to the TICKET SETTING screen.

#### ■Menu Item

VALUE OF PLAY	Set monetary cost per play. Every time the test button is pressed, the number will display in the order +0.01 from 0.2 to 2.0. 1.00 is set by default.
VALUE OF TICKET	Set monetary value of each ticket. Every time the test button is pressed, the number will display in the order +0.01 from 0.01 to 0.10. Under 0.01, you can set 0.001, 0.002, 0.005. 0.01 is set by default.
TICKET DENOMINATION	This setting is used only if the game is using 2 points ticket. If you are using a 2 points ticket, set this value to 2. 1 is set by default.
AIMING PERCENTAGE	Set targeting percentage. Every time the test button is pressed, the number will display in the order +5 from 5% to 80%. 30% is set by default.
RESET SETTINGS	Set all of the DIFFICULTY SETTINGS back to the factory default values.

#### Please note:

If any changes are made to either DIFFICULTY settings or VALUE settings then it is recommended that the BACK UP DATA is also cleared. Please refer to Section 9-20 (Page 74) of this manual.

## 9-20 BACKUP DATA CLEAR

### BACKUP DATA CLEAR

Clear all game records

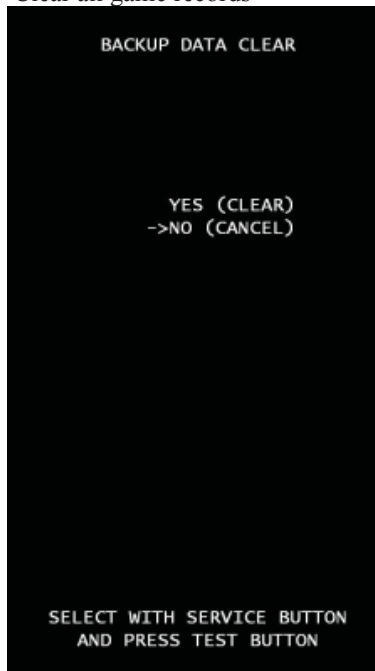

#### ■Control

\*Press SERVICE button to select menu item.

\*Select "YES (CLEAR)" and press TEST button to clear all backup data. When "COMPLETED" is displayed, press TEST button again and return to GAME TEST MODE screen.



\*\*\*Select "NO (CANCEL)" and press TEST button, no action will be executed and return to GAME TEST MODE screen directly.

## 9-21 TICKET ERROR

### Ticket Dispenser Error

#### EMPTY ERROR

This message will be displayed immediately in game mode if the tickets are not filled and set in ticket BIN & Dispenser. Fill tickets and press Ticket Release Switch to back normal.

#### JAM ERROR

This message will appear when ticket(s) are jammed on TICKET DISPENSER. After remove jammed tickets then fill the tickets correctly then press Ticket Release Switch to back normal.

#### MAX TICKETS ERROR

This message will be appeared when the ticket payout numbers over the number that set at MAXIMUM TICKETS DISPENSE. Verify the ticket number on screen then press Ticket Release Switch to back normal.

## 10 CONTROLLER UNIT(S)

### WARNING

- When working with the product, be sure to turn the power off. Working with the power on may cause an electric shock or short circuit.
- Be careful not to damage the wires. Damaged wires may cause an electric shock, short circuit or present a risk of fire.
- Exercise due caution in performing soldering work. If soldering iron is handled carelessly, there could be fires or burns.

### CAUTION

- When fastening plastic parts, be careful not to tighten screws or nuts excessively. If these are tightened to excess, parts could be damaged, resulting in injuries from fragments, etc.
- After the unit has been disassembled and reassembled again, check carefully that the unit has been reassembled correctly.

### STOP IMPORTANT

- Once the product has been disassembled, use slack preventive agent. Coat screws with suitable amounts of this agent and then tighten them. If this agent is not used, the product might start rattling or come apart.
- Use the slack preventive agent prescribed in these instructions. If any other agent is used, there could be chemical changes that inhibit the use of screws and part surfaces could be damaged.
- Be careful not to damage or lose small parts or screws.
- When a part has been replaced, be sure to always make adjustments and check conditions in Test Mode.

## STOP IMPORTANT

Be sure to perform TEST in the INPUT ASSIGNMENTS in the Game Test Mode after replacing or adjusting switches.

### 10-1 REMOVING THE CONTROLLER

A 5 mm hexagonal wrench is required for the following procedure.

- 1 Turn off the power.
- 2 Remove the 8 hexagon socket button head screws from both sides of the Control Panel's front and back.
- 3 Gentle lift the Control Panel Cover and place to one side.

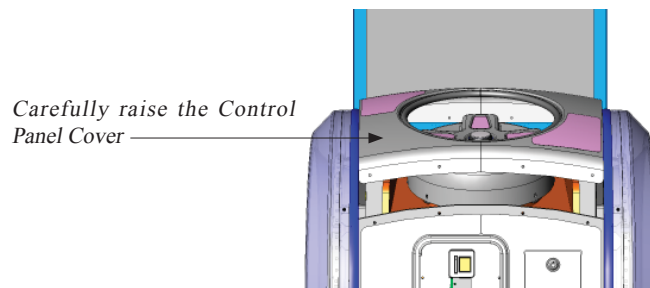
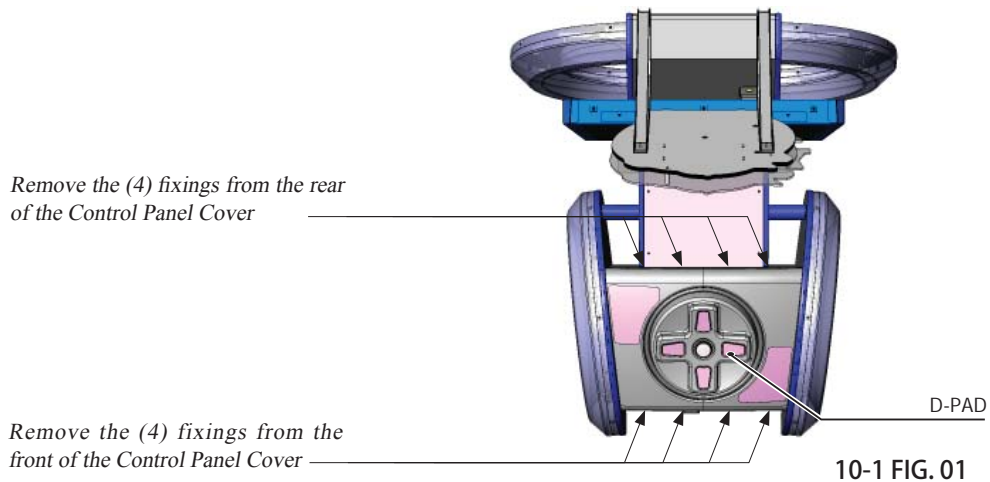



- 4 Locate the (6) fixings, 3 positioned either side of the D-Pad and remove.
- 5 Once all (6) fixings have been removed, carefully lift the D-Pad.
- 6 Once the D-pad has cleared the mechanics of the Controller, carefully overturn the D-Pad cover to locate the Button and Button harness.
- 7 Holding the Lamp housing between your finger and thumb, gently twist as you pull the Lamp housing away from the Button housing

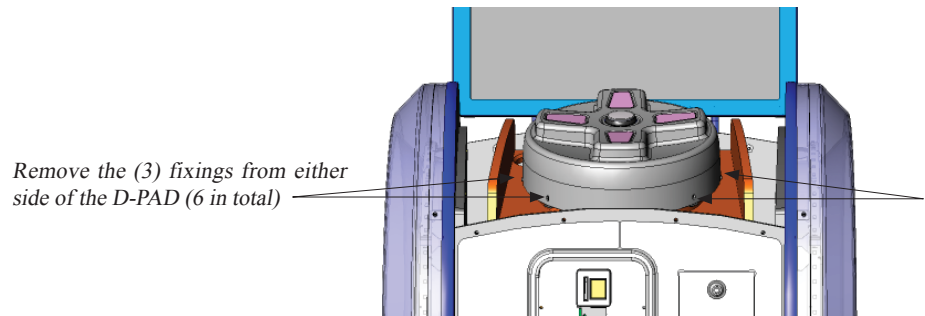

10-1 FIG. 03

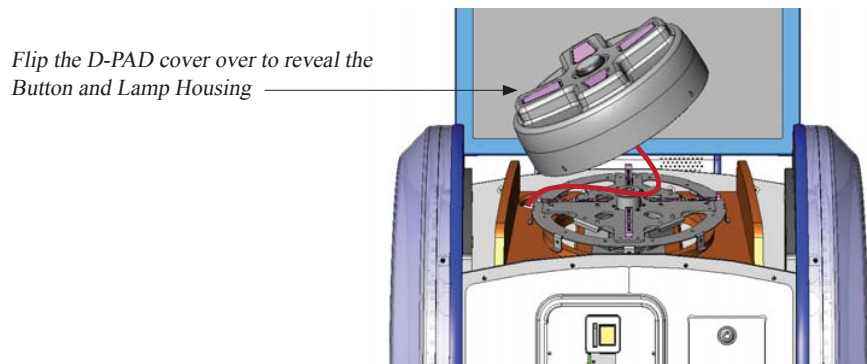

10-1 FIG. 04

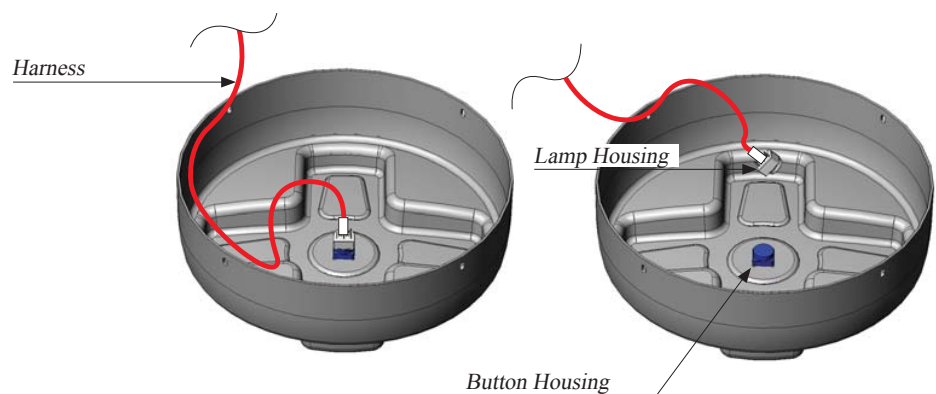

10-1 FIG. 05

## BULB/LED REPLACEMENT

### STOP IMPORTANT

- Be sure to replace the lamp like for like. Replacing the lamp or LED with a different type/value may cause malfunction, electrical component failure or even a fire hazard.
- Take care when replacing 'Glass' bulbs. The integrity of a glass bulb may be impaired. Use protective gloves and/or eye wear when removing as the glass may shatter and cause injury.

IMPORTANT: This game uses an LED within the DASH Button Assy.

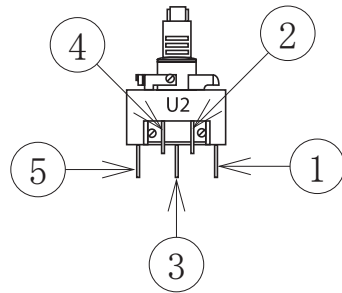

10-2 FIG. 06

### Connections

Pin 1	NC
Pin 2	-ve
Pin 3	NO
Pin 4	+ve
Pin 5	COM

# 11 GRAPHICS DISPLAY

## 11

### GRAPHICS DISPLAY

#### 11-1 SAFETY PRECAUTIONS WHEN HANDLING THE MONITOR

##### WARNING

###### Responding to breakdown or abnormality

- If smoke or a strange odor appears, immediately unplug the power cable from the power source.

Continuing to use the product may cause a fire or an electric shock. Ensure that smoke is no longer emitted, and contact the point of purchase.

- If nothing displays on the screen, immediately unplug the power cable from the power source.

Continuing to use the product may cause a fire or an electric shock. Contact the point of purchase and request an inspection.

- If water or a foreign object enters the monitor's interior, immediately unplug the power cable from the power source.

Continuing to use the product may cause a fire or an electric shock. Contact the point of purchase and request an inspection.

- If the monitor is dropped or the cabinet is damaged, immediately unplug the power cable from the power source.

Continuing to use the product may cause a fire or an electric shock. Contact the point of purchase and request an inspection.

###### During operation

- Do not repair, reconstruct, or disassemble the monitor.

The monitor's interior contains high voltage parts. A fire or an electric shock could result.

For inspections, adjustments, and repair of the monitor's interior, request work from the point of purchase.

- Do not insert foreign objects.

If metal objects or flammable materials such as paper are inserted into the interior through ventilation openings or other apertures, an electric shock could result.

- In the event of a thunder storm, do not touch the product or the power cable. An electric shock could result.

- Make sure to perform appropriate adjustments. Do not operate the product when the screen is flickering, distorted, or experiencing other abnormalities. Images from an improperly adjusted screen could cause players and other customers to experience dizziness, headaches, and other ailments.

## 11-2 CLEANING THE SCREEN SURFACE

### CAUTION

- Use a soft, dry cloth (flannel-type) to wipe away dirt. Do not use materials such as coarse mesh gauze.
- Alcohol (ethanol) is the recommended solvent for removing dirt. When using a cleaning agent, follow the precautions below.
  - Dilute neutral cleaning agents for home use with water. Soak a soft cloth in the solution, and wring it thoroughly before wiping the screen.
  - Do not use abrasive cleaning agents or powders, or cleaning agents containing bleach.
  - Do not use alkaline cleaning agents such as glass cleaners, or solvents such as thinners.
- Do not scrub or scratch the screen surface with abrasive materials such as brushes or scrub brushes.

**CLEAN THE SCREEN DAILY.**

## 11-3 ADJUSTMENT METHOD

### **STOP** IMPORTANT

All adjustment values are set accurately at the time of shipping from the factory. Do not readjust these values needlessly or apply adjustments not specified in this manual. The display may not appear properly if the values are incorrect.

### CONTROL - ADJUSTMENT PROCEDURE

This section explains basic control procedures for making adjustments using the buttons on the 'Monitor Adjustment Board'

This Adjustment Board, and the Monitor Power Supply are located behind the Rear Door.

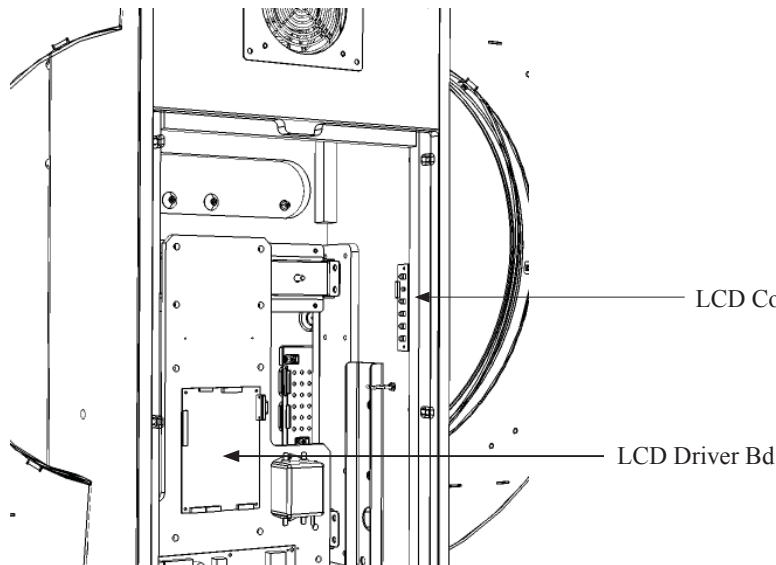
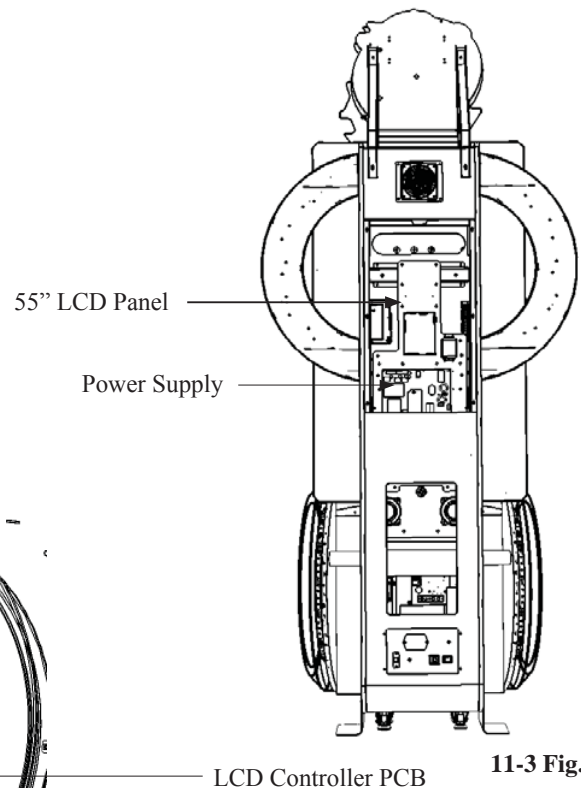

## 11-3 ADJUSTMENT METHOD

### Button Names and Functions

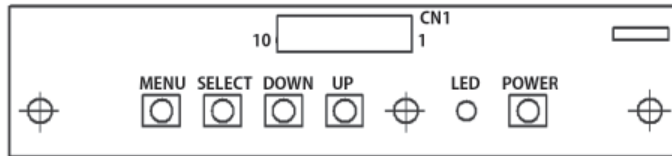

11-3 Fig. 03

**MENU:** Turn the Picture Menu display ON and OFF.

**SELECT:** Gains entry to the Item selected in the menu. (Highlights in Yellow when selected)  
Exits the Item adjustment. Any changes made during this operation are actioned.

**DOWN:** Moves the cursor (Black Bar) down to select a menu item.  
Decrease the value of, or change, a selected menu item.

**UP:** Move the cursor (Black Bar) up to select a menu item.  
Increase the value of, or change, a selected menu item.

**LED:** LED illuminates green: Monitor is operating.  
LED flashes red: Power is off.

**POWER:** Turns the LCD Display ON and OFF. (Usually, it's not necessary to operate.)

## 11-3 ADJUSTMENT METHOD

### On-Screen Display (OSD)

Press the MENU Button while the OSD is not displayed to bring up the Picture Menu.  
On the Picture Menu, it is possible to perform various screen adjustments.

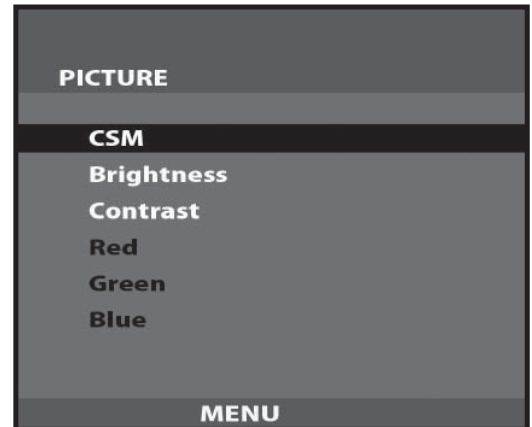

11-3 Fig. 04

Use the UP and DOWN Buttons to move the 'Black Bar'to the item you want to adjust.  
After selecting the desired item, pressing the SELECT Button will extend the MENU Screen and allow adjustments to be changed.

Within each item, press the SELECT Button to exit the adjustment screen. The adjustment values at this time will be saved simultaneously.

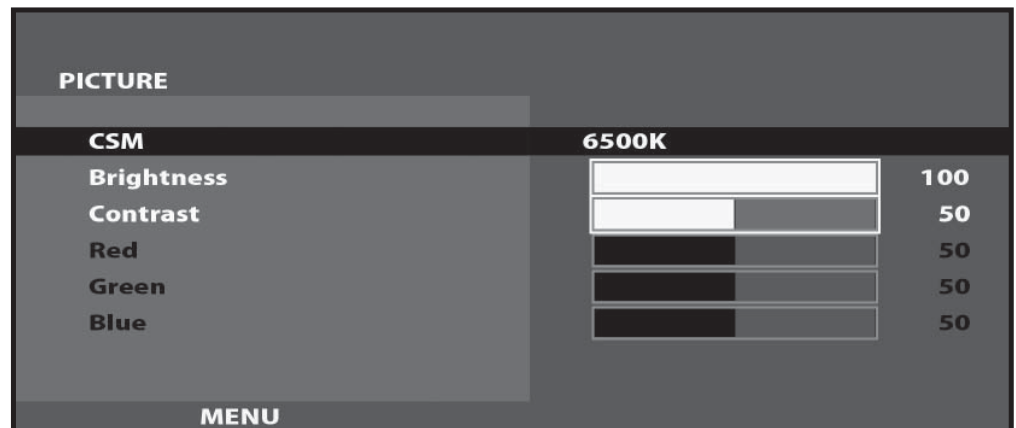

11-3 Fig. 05

The current options are set at :

CSM	-	6500K
Brightness	-	100
Contrast	-	50

## 11-3 ADJUSTMENT METHOD

### On-Screen Display (OSD) <continued>

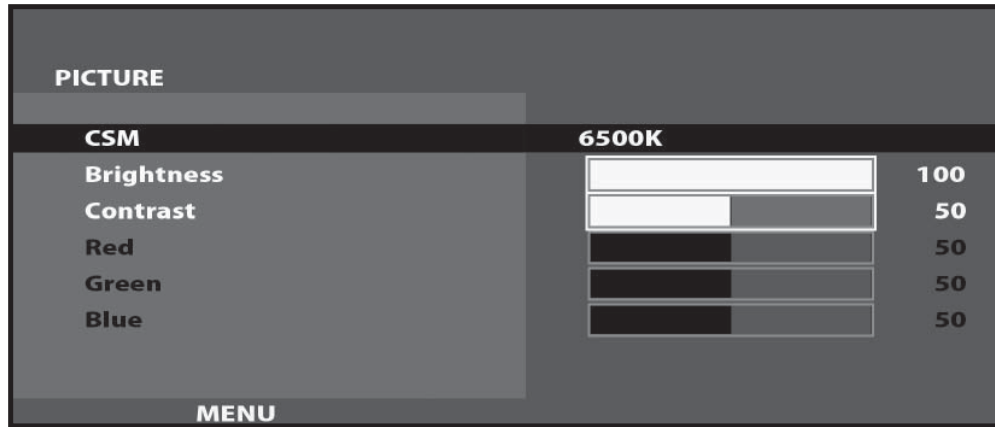

11-3 Fig. 06

### Available Settings

**CSM** (Selects Operation Mode)  
Selection available - 6500K - 9300K - USER

**BRIGHTNESS** (Adjust Brightness)  
Adjust screen Brightness. - Values: 0 - 100  
(0" being the darkest setting, and "100" being the brightest)

**CONTRAST** (Adjust Contrast)  
Adjust Contrast level. - Values: 0 - 100  
(0" having the least amount of difference between light and dark, and "100" having the most)

**NOTE :** The Red, Green, and Blue adjustments are unavailable in the Mode of Operation selected on the Screen shown in 11-3 Fig. 06. These adjustments can only be made is the CSM option is set to 'User'.



## 12 COIN HANDLING

### Handling the Coin Jam

If the coin is not rejected when the REJECT button is pressed, open the coin chute door and open the selector gate. After removing the jammed coin, put a normal coin in and check to see that the selector correctly functions.

### 12-1 CLEANING THE COIN SELECTOR

#### STOP IMPORTANT

- Remove and clean smears by using a soft cloth dipped in water or diluted chemical detergent and then squeezed dry.
- Never apply machine oil, etc. to the Coin Selector.
- After cleaning the Coin Selector, insert a regular coin in the normal working status and ensure that the selector correctly functions.

The Coin Selector should be cleaned once every 3 months.  
When cleaning, follow the procedure below:

- 1 Turn the power for the machine OFF. Open the Coin Chute Door
- 2 Remove the Coin Selector from the Coin Chute Door
- 3 Open the gate and dust off by using a soft brush (Small soft Paint Brush, etc.)

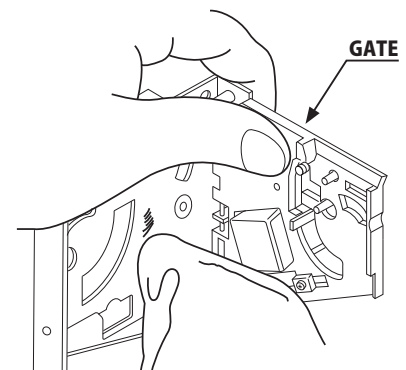

12-1 FIG 1

## CLEANING THE COIN SELECTOR (MECHANICAL).

- 1** Remove and clean smears by using a soft cloth dipped in water or diluted chemical detergent and then squeezed dry.
- 2** Remove the CRADLE.. When removing the retaining ring (E ring) be very careful so as not to bend the rotary shaft.
- 3** Remove stain from the rotary shaft and shaft receiving portions by wiping off with a soft cloth. etc.
- 4** After wiping off as per previous step, further apply a dry cloth to completely dry the Coin Selector.

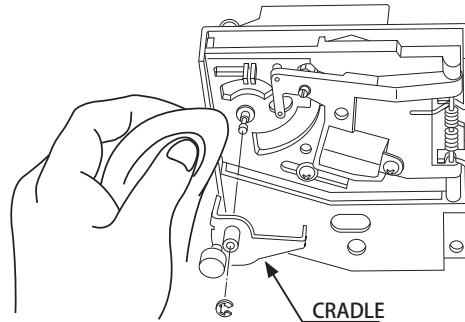

12-1 FIG 2

### Coin Insertion Test

Once every month, when performing the Coin SW Test, simultaneously check the following:

Does the Coin Meter count satisfactorily?

Does the coin drop into the cashbox correctly?

Is the coin rejected when inserted while keeping the REJECT Button pressed down?

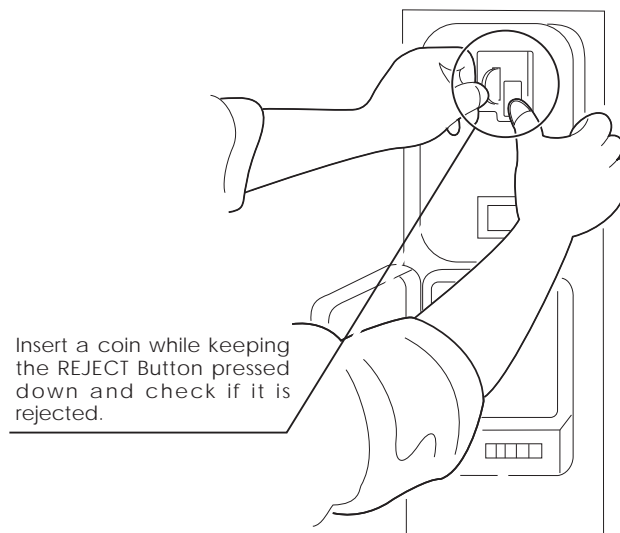

12-1 FIG 3

## CLEANING THE COIN SELECTOR (SR3/NRI) <continued>

12

COIN HANDLING

- 1 Remove and clean smears by using a damp soft cloth dipped in water. DO NOT use any diluted chemical detergent or cleansing agent as this will impair the workings of the component.

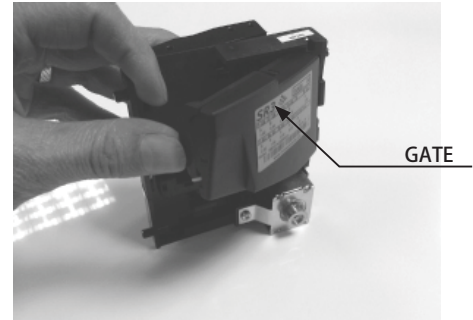

- 2 Open the reject gate to gain access to the rundown path.

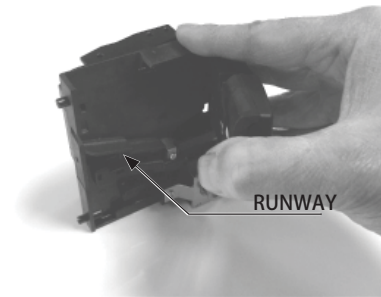

- 3 Remove the dirt and stains from the runway by wiping off with a soft damp cloth.

- 4 After wiping off as per previous step, further apply a dry cloth to completely dry the coin Selector.



## 12-2 FAULT FINDING

### Fault Finding

The following information is presented for customers' guidance in rectifying a fault but does not cover all possible causes.

All acceptors with electronic faults should be returned to an approved service centre for repair.

SYMPTOM	INVESTIGATE	POSSIBLE CAUSE
Acceptor does not work (all coins reject)	Connector	Poor Contact
		Loose Wire
	Power Supply	Not switched on
		Incorrect voltage
		Inadequate current
		Rise time too slow
	Inhibit all inputs	Acceptor Inhibited
	Accept gate	Gate not free or dislocated
	Accept channel	Obstruction
	Reject gate	Not fully closed
	LED on rear cover RED	EEPROM chksm error
		SR Sensor fault
Credit opto fault		
Credit sensor blocked		
LED on rear cover YELLOW	Reject lever pressed	
	Reinstall power	
Poor Acceptance	Power Supply	Voltage less than 10v (Voltage drops when coil engages)
	Accept gate	Gate jam or dislocated
	Connector	Loose
	Coin rundown	Dirty
	Bank Select	Both banks enabled
Coin stick or jam in acceptor.	Accept channel	Acceptor dirty or may have some damage
	Accept gate	
	Reject gate	
A true coin type rejects	Label	Coin not programmed
No accept signal	Connector	Loose or broken wire
	Accept channel	Path dirty or obstructed

## 12-3 ADJUSTING THE PRICE OF PLAY (EXCEL)

### STOP IMPORTANT

- The price of play is determined by the configuration of switches located on either an EXCEL board or VTS board. The type of board used is determined by product location. Switch settings for both types of board remain the same.

This product comes equipped with a Money Controls SR3 Coin Acceptor. To adjust the price of play ALL credit settings are adjusted via the EXCEL CREDIT BOARD.

#### IMPORTANT!

The CREDIT SETTINGS within the SYSTEM TEST MODE must be set to 1 coin 1 credit to allow the CREDIT BOARD to function correctly.

The VTS BD has a built in Credit Board. This is controlled by 2 DIL Switches. These allow the operator to select the price of play, type of coin acceptor and region.

#### EXCEL Credit Board

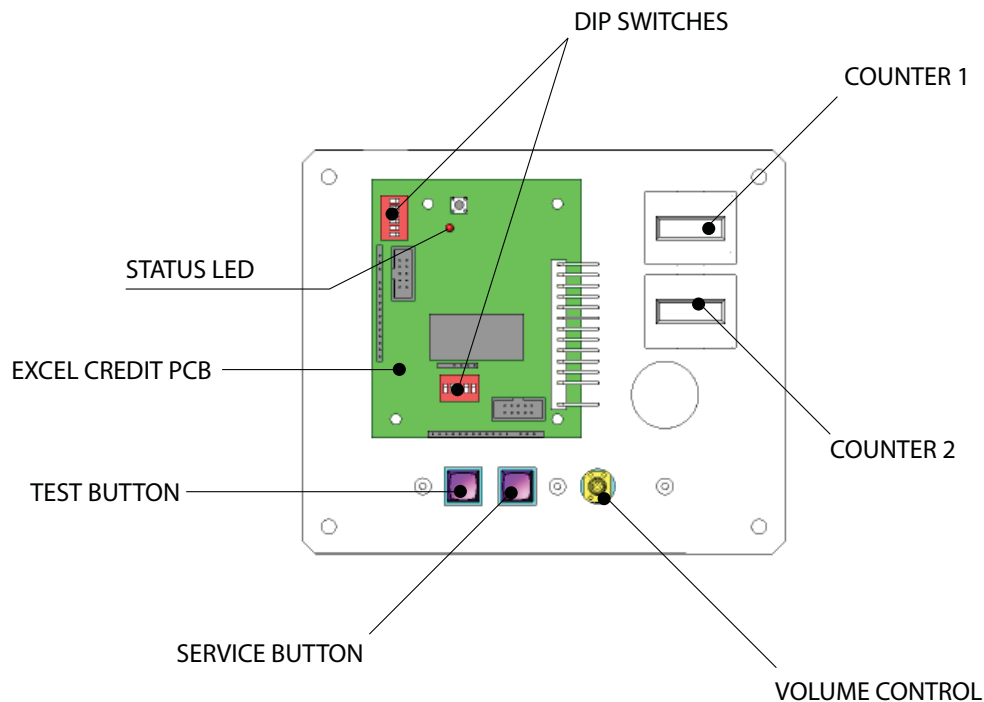

#### DIL SW3 (Regional Settings)

Adjust these switches to specify the type of Coin Acceptor used and currency.

Default = SW1&SW2 ON - SR3 in parallel mode, Sterling.

#### TEST BUTTON

Provides access to the TEST MENU when pressed.

#### SERVICE BUTTON

Provides a SERVICE CREDIT when pressed

#### Status LED

Flashes when functioning.

#### CHANNEL 1

To Coin Acceptor (SR3 TYPE.)

#### DIL SW1 (credit settings)

Adjust to required price of pay.

#### VOL CONTROL

MAIN VOLUME ADJUSTMENT (FRONT SPEAKERS)

Country	Setting	Switch 3 Setting					Credit Board Mode Settings Switch 3											
		SW1	SW2	SW3	SW4	SW5	SW6	Coin Validator Programming						C120/SR3 Only				
							COIN1	COIN2	COIN3	COIN4	COIN5	COIN6	COIN7	COIN8	COIN9	COIN10	COIN11	COIN12
UK	Coin Controls C220 Parallel	OFF	OFF	OFF	OFF		£1	50p new	20p	10p	-	50p old	-	-	-	-	-	-
UK	Coin Controls C220 Binary	ON	OFF	OFF	OFF		£1	50p new	20p	10p	-	50p old	-	£2	-	-	-	-
UK	Coin Controls C220 Binary	OFF	ON	OFF	OFF		£1	50p new	20p	10p	-	£2	-	50p old	-	-	-	-
UK	Coin Controls SR3 Parallel	ON	ON	OFF	OFF		£1	50p new	20p	10p	-	£2	-	50p old	-	-	-	-
UK	Coin Controls SR3 Parallel	OFF	OFF	ON	OFF		£2	£1	50p new	20p	10p	-	-	-	-	50p old	-	-
Euro	Coin Controls SR3 Parallel	ON	OFF	ON	OFF		£2	£1	50p new	20p	10p	-	-	-	-	-	-	-
UK	Mars MEMS 111 Parallel	ON	OFF	ON	OFF		£1	£2	20p	10p	50p new	50p old						
UK	NRI Parallel	OFF	ON	ON	OFF		10p	20p	50p	£1	£2	-	-	-	-	-	-	-
Belgium	Parallel	ON	ON	ON	OFF		-	50Bfr	20Bfr	5Bfr								
Holland	Parallel	OFF	OFF	OFF	ON		-	5NLG	2.5NLG	1NLG								
Austria	SR3 Parallel	ON	OFF	OFF	ON		20Sch	10Sch	55Sch	15Sch								
Spain	Coin Controls C220 Binary	OFF	ON	OFF	ON		500Pta	200Pta	100Pta	50Pta	25Pta	200Pt old	50Pta old	25Pta old	25Pta old			
Spain	SR3/NRI Parallel	ON	ON	OFF	ON		500Pta	200Pta	100Pta	50Pta	25Pta	-	-	200Pta old	-	50Pta old	25Pta old	-
Spain	Coin Controls C220 Parallel	OFF	OFF	ON	ON		100Pta	50Pta new	-	25Pta new	-	50Pta old	-	25Pta old				
Portugal	Parallel	ON	OFF	ON	ON		200Es	100Es	50Es	-	-	-	-	-	-	-	-	-
Euro	TBA				OFF		TBA	TBA										
					ON		TBA	TBA										
	Channels				OFF		Direct Mode	2 channel Mode										

Note: These switch settings are under constant review and may change due to world currency updates.

Set SW 1 according to the option settings found in the relevant Price of Play Settings Table on the following pages.

Set SW 3 on the VTS /Excel board as shown in the table above corresponding to the country required.

**REGIONAL AND ACCEPTOR SETTINGS (SW3)**

**STERLING PRICE OF PLAY SETTINGS (SW1)**

Price	Bonus					DIL Switch 1				
	1	2	3	4	5	1	2	3	4	5
1 10p	50p = 5 plays	£1 = 10 plays	£2 = 20 plays			OFF	OFF	OFF	OFF	OFF
2 10p	50p = 6 plays @ 8.33p per play	£1 = 12 plays @ 8.33p per play	£2 = 24 plays @ 8.33p per play			ON	OFF	OFF	OFF	OFF
3 20p	50p = 2.5 plays	£1 = 5 plays	£2 = 10 plays			OFF	ON	OFF	OFF	OFF
4 20p	50p = 3 plays @ 16.66p per play	£1 = 6 plays @ 16.66p per play	£2 = 12 plays @ 16.66p per play			ON	ON	OFF	OFF	OFF
5 30p	50p = 1.66 plays	£1 = 3.33 plays	£2 = 6.66 plays			OFF	OFF	ON	OFF	OFF
6 30p	50p = 1.66 plays	£1 = 4 plays @ 25p per play	£2 = 8 plays @ 25p per play			ON	OFF	ON	OFF	OFF
7 30p	50p = 2 plays @ 25p per play	£1 = 4 plays @ 25p per play	£2 = 8 plays @ 25p per play			OFF	ON	ON	OFF	OFF
8 30p	50p = 2 plays @ 25p per play	£1 = 3 plays @ 33.33p per play	£2 = 6 plays @ 33.33p per play			ON	ON	ON	OFF	OFF
9 40p	50p = 1.25 plays	£1 = 2.5 plays	£2 = 5 plays			OFF	OFF	OFF	ON	OFF
10 40p	50p = 1.25 plays	£1 = 3 plays @ 33.3p per play	£2 = 6 plays @ 33.3p per play			ON	OFF	OFF	ON	OFF
11 50p	50p = 1 play	£1 = 2 plays	£2 = 4 plays			OFF	ON	OFF	ON	OFF
12 50p	50p = 1 play	£1 = 3 plays @ 33.3p per play	£2 = 6 plays @ 33.3p per play			ON	ON	OFF	ON	OFF
13 50p	50p = 1 play	£1 = 2 plays	£2 = 5 plays @ 40p per play			OFF	OFF	ON	ON	OFF
14 60p	50p = 0.83 play	£1 = 1.66 plays	£2 = 3.33 plays			ON	OFF	ON	ON	OFF
15 60p	50p = 0.83 play	£1 = 2 plays @ 50p per play	£2 = 4 plays @ 50p per play			OFF	ON	ON	ON	OFF
16 80p	50p = 0.62 play	£1 = 1.25 plays	£2 = 2.5 plays			ON	ON	ON	ON	OFF
17 80p	£1 = 1.25 plays	£1.50 = 2 plays @ 75p per play	£2 = 2.5 plays			OFF	OFF	OFF	OFF	ON
18 £1	2x50p = 1 play	£1 = 1 play	£2 = 2 plays			ON	OFF	OFF	OFF	ON
19 £1	2x50p = 1 play	£1 = 1 play	£2 = 3 plays @ 66.6p per play			OFF	ON	OFF	OFF	ON
20 £1	2x50p = 1 play	£2 = 2 plays	£4 = 5 plays @ 80p per play			ON	ON	OFF	OFF	ON
21 £1.50	3x50p = 1 play	£1 = 0.66 plays	£3 = 2 plays			OFF	OFF	ON	OFF	ON
22 £1.50	3x 50p = 1 play	£1 = 0.66 plays	£2 = 2 plays @ £1 per play			ON	OFF	ON	OFF	ON
23 £2	4x 50p = 1 play	£1 = 0.5 play	£2 = 1 play			OFF	ON	ON	OFF	ON
24 £2	4x 50p = 1 play	£1 = 0.5 play	£5 = 3 plays @ £1.66 per play			ON	ON	ON	OFF	ON
25 £3	6x50p = 1 play	£1.50 = 0.5 play	£3 = 1 play			OFF	OFF	OFF	ON	ON
26 £3	6x50p = 1 play	£1.50 = 0.5 play	£5 = 2 plays @ £2.50 per play			ON	OFF	OFF	ON	ON
27 £5	£1 = 0.2 play	£5 = 1 play	£10 = 2 plays			OFF	ON	OFF	ON	ON
28 £5	£1 = 0.2 play	£5 = 1 play	£10 = 3 plays @ £3.33p per play			ON	ON	OFF	ON	ON
29 £7.50	£5 = 0.66 play	£10 = 1.33 plays	£15 = 2 plays			OFF	OFF	ON	ON	ON
30 £7.50	£5 = 0.66 play	£10 = 1.33 plays	£10 = 2 plays @ £5 per play			ON	OFF	ON	ON	ON
31 £10	£10 = 1 play	£20 = 2 play	£30 = 3 play			OFF	ON	ON	ON	ON
32	Free Play					ON	ON	ON	ON	ON



## EURO PRICE OF PLAY SETTINGS (SW1)

	Price	Bonus					DIL Switch 1				
							1	2	3	4	5
1	10¢	50¢ = 5 plays	€1 = 10 plays	€2 = 20 plays		OFF	OFF	OFF	OFF	OFF	
2	10¢	50¢ = 6 plays @ 8.33p per play	€1 = 12 plays @ 8.33¢ per play	€2 = 24 plays @ 8.33¢ per play		ON	OFF	OFF	OFF	OFF	
3	20¢	50¢ = 2.5 plays	€1 = 5 plays	€2 = 10 plays		OFF	ON	OFF	OFF	OFF	
4	20¢	50¢ = 3 plays @ 16.66¢ per play	€1 = 6 plays @ 16.66¢ per play	€2 = 12 plays @ 16.66¢ per play		ON	ON	OFF	OFF	OFF	
5	30¢	50¢ = 1.66 plays	€1 = 3.33 plays	€2 = 6.66 plays		OFF	OFF	ON	OFF	OFF	
6	30¢	50¢ = 1.66 plays	€1 = 4 plays @ 25¢ per play	€2 = 8 plays @ 25¢ per play		ON	OFF	ON	OFF	OFF	
7	30¢	50¢ = 2 plays @ 25¢ per play	€1 = 4 plays @ 25¢ per play	€2 = 8 plays @ 25¢ per play		OFF	ON	ON	OFF	OFF	
8	30¢	50¢ = 2 plays @ 25¢ per play	€1 = 3 plays @ 33.33¢ per play	€2 = 6 plays @ 33.33¢ per play		ON	ON	ON	OFF	OFF	
9	40¢	50¢ = 1.25 plays	€1 = 2.5 plays	€2 = 5 plays		OFF	OFF	OFF	ON	OFF	
10	40¢	50¢ = 1.25 plays	€1 = 3 plays @ 33.33¢ per play	€2 = 6 plays @ 33.33¢ per play		ON	OFF	OFF	ON	OFF	
11	50¢	50¢ = 1 play	€1 = 2 plays	€2 = 4 plays		OFF	ON	OFF	ON	OFF	
12	50¢	50¢ = 1 play	€1 = 3 plays @ 33.33¢ per play	€2 = 6 plays @ 33.33¢ per play		ON	ON	OFF	ON	OFF	
13	50¢	50¢ = 1 play	€1 = 2 plays	€2 = 5 plays @ 40¢ per play		OFF	OFF	ON	ON	OFF	
14	60¢	50¢ = 0.83 play	€1 = 1.66 plays	€2 = 3.33 plays		ON	OFF	ON	ON	OFF	
15	60¢	50¢ = 0.83 play	€1 = 2 plays @ 50¢ per play	€2 = 4 plays @ 50¢ per play		OFF	ON	ON	ON	OFF	
16	80¢	50¢ = 0.62 play	€1 = 1.25 plays	€2 = 2.5 plays		ON	ON	ON	ON	OFF	
17	80¢	€1 = 1.25 plays	€1.50 = 2 plays @ 75¢ per play	€2 = 2 plays		OFF	OFF	OFF	OFF	ON	
18	€1	2x50¢ = 1 play	€1 = 1 play	€2 = 2 plays		ON	OFF	OFF	OFF	ON	
19	€1	2x50¢ = 1 play	€1 = 1 play	€2 = 3 plays @ 66.6¢ per play		OFF	ON	OFF	OFF	ON	
20	€1	2x50¢ = 1 play	€2 = 2 plays	€4 = 5 plays @ 80¢ per play		ON	ON	OFF	OFF	ON	
21	€1.50	3x50¢ = 1 play	€1 = 0.66 plays	€3 = 2 plays		OFF	OFF	ON	OFF	ON	
22	€1.50	3x 50¢ = 1 play	€1 = 0.66 plays	€2 = 2 plays @ €1 per play		ON	OFF	ON	OFF	ON	
23	€2	4x 50¢ = 1 play	€1 = 0.5 play	€2 = 1 play		OFF	ON	ON	OFF	ON	
24	€2	4x 50¢ = 1 play	€1 = 0.5 play	€5 = 3 plays @ €1.66 per play		ON	ON	ON	OFF	ON	
25	€3	6x50¢ = 1 play	€1.50 = 0.5 play	€3 = 1 play		OFF	OFF	OFF	ON	ON	
26	€3	6x50¢ = 1 play	€1.50 = 0.5 play	€5 = 2 plays @ €2.50 per play		ON	OFF	OFF	ON	ON	
27	€5	€1 = 0.2 play	€5 = 1 play	€10 = 2 plays		OFF	ON	OFF	ON	ON	
28	€5	€1 = 0.2 play	€5 = 1 play	€10 = 3 plays @ 3.33¢ per play		ON	ON	OFF	ON	ON	
29	€7.50	€5 = 0.66 play	€10 = 1.33 plays	€15 = 2 plays		OFF	OFF	ON	ON	ON	
30	€7.50	€5 = 0.66 play	€10 = 1.33 plays	€10 = 2 plays @ €5 per play		ON	OFF	ON	ON	ON	
31	€10	€10 = 1 play	€20 = 2 play	€30 = 3 play		OFF	ON	ON	ON	ON	
32		Free Play					ON	ON	ON	ON	ON



## 13 LAMPS AND LIGHTING

### ⚠ WARNING

- When working with the product, be sure to turn the power off. Working with the power on may cause an electric shock or short circuit.
- You may get burned by a hot fluorescent lamp or other lamps. Pay full attention to the lamps when performing the work.
- Be sure to use lamps of the designated rating. Using lamps of undesignated rating can cause a fire or malfunctioning.
- There is the danger of short circuits or smoke generation due to deterioration of insulation in lighting fixtures resulting from age deterioration. Check for anomalies such as the following: Does it smell like something is burning? Is there socket discoloration? Are any lamps being replaced frequently? Do lamps not go on properly?

### ⚠ CAUTION

The Coin Door Lamp utilises a 12v 1.2w Wedge Bulb. It is important that you replace this bulb or any other bulb of that of the same voltage and rating. Failing to observe this caution may result in PCB failure or possible fire hazard.

### 13-1 COIN DOOR LAMP

Step 1. Open the Coin Door and locate the Lamp Housing directly behind the Coin Insert Bezel. 

Step 2. Hold the Lamp Housing firmly between your index finger and thumb and gently pull upwards. Do Not try to remove the Lamp Housing whilst holding the bulb as the bulb may break causing injury.

Step 3. Once the Lamp Housing has been removed, carefully hold the bulb between your fingers and pull the Lamp Housing away.

Do not twist either bulb or Lamp Housing whilst removing the bulb as this may cause damage to both bulb and or Housing.

Type: Wedge Bulb - 12v, 1.2w 

Step 4. Simply push-fit a replacement bulb of the same type and follow these steps in reverse to refit.

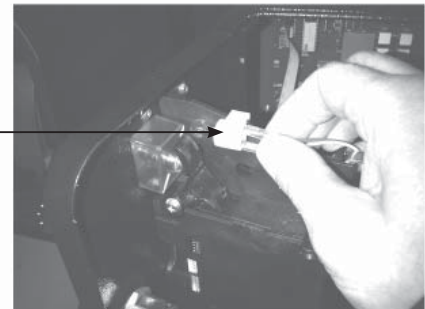

## 13-2 BILLBOARD LED LIGHTING

### WARNING

THIS WORK ON TOP OF THE CABINET, SHOULD NOT BE UNDERTAKEN WITHOUT THE USE OF A SUITABLE STEP OR FOOTSTOOL.

### WARNING

MAKE SURE THAT THE MAIN SUPPLY VOLTAGE TO THE MACHINE IS SWITCHED OFF AND UNPLUGGED BEFORE ATTEMPTING TO CARRY OUT THIS WORK

**1** The Billboard LED's are located between the back section of the Billboard and the front Artwork, before attempting to change the Tube, TURN THE POWER OFF.

**2** To gain access to the outer LED strips, extract the (3) M4x50 TMP BH PAS (008-B00450) fixing screws which hold the Billboard Title Panel in place and remove.

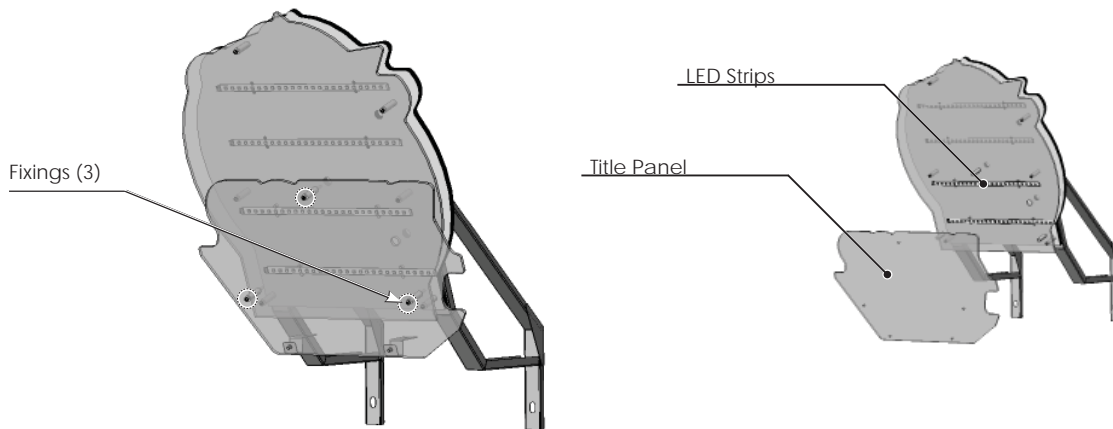

**3** Depending on which LED strip to replace, remove the relevant cable ties which support the LED strip to the Billboard and remove.

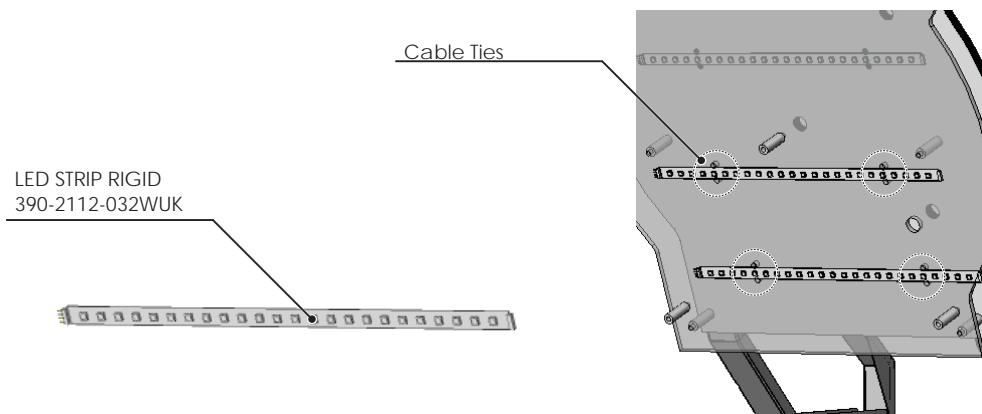

- 4** Using a sharp handled blade, carefully strip back the protective sleeving to reveal the solder joint. Using a Soldering Iron carefully unsolder the harness from the defective LED strip.

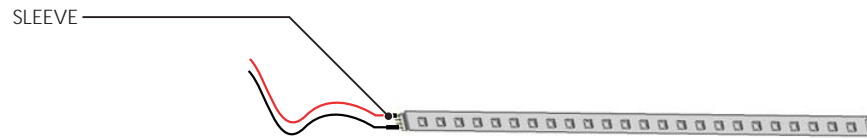

- 5** Once the harness has been successfully removed from the LED strip, resolder it to the replacement LED making note of the polarity. If the connections are reversed the LED will not light and may cause damage to the PCB.

- 6** To gain access to the inner LED strip, follow steps 1 and 2 then locate the 6 M4x50 TMP BH PAS (008-B00450) fixing which hold the outer Billboard in place and remove.

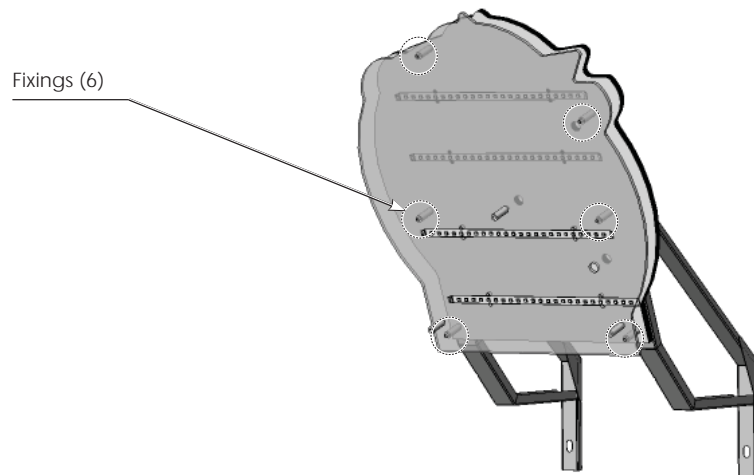

- 7** Using the same method in STEPS 3, 4 and 5 remove the defective LED strip and replace. Reassemble in reverse order.

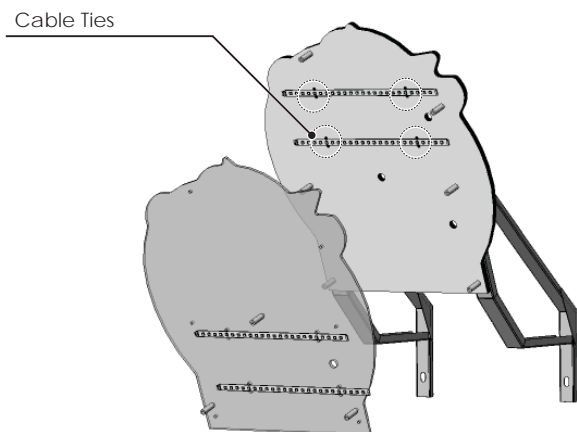

## 13-3 HALF HOOP LED LIGHTING

### **⚠ WARNING**

THIS WORK ON TOP OF THE CABINET, SHOULD NOT BE UNDERTAKEN WITHOUT THE USE OF A SUITABLE STEP OR FOOTSTOOL.

### **⚠ WARNING**

MAKE SURE THAT THE MAIN SUPPLY VOLTAGE TO THE MACHINE IS SWITCHED OFF BEFORE ATTEMPTING TO CARRY OUT THIS WORK

- 1 To remove the HALF HOOP Outer cover, locate and remove the (7) M4x12 SKT BH PAS (029-B00412). Remove (4) from the outer edge and (3) from the inner edge.

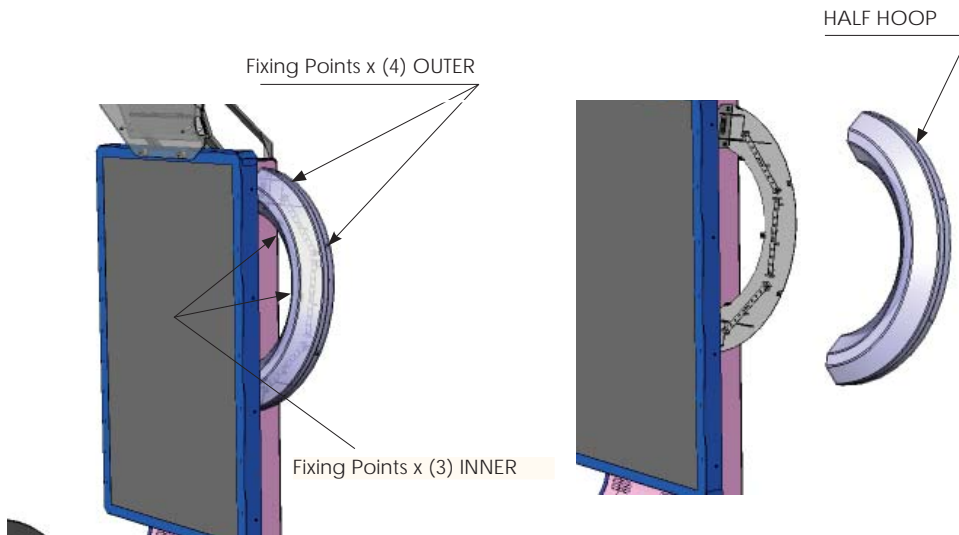

- 2 Once the outer cover is removed, disconnect the suspected LED Bd at both ends and remove the (4) M3x16 SKT BH BLK fixings which secure the LED Bd to the metal frame.

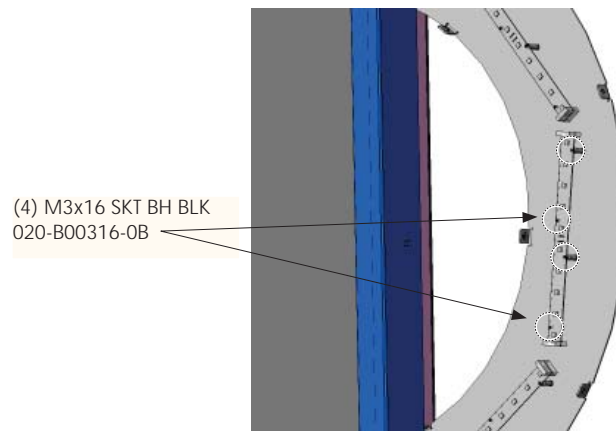

- 
- 3** Replace the defective LED board with that of the same type. HALF RING LED BD (601-13101-001)

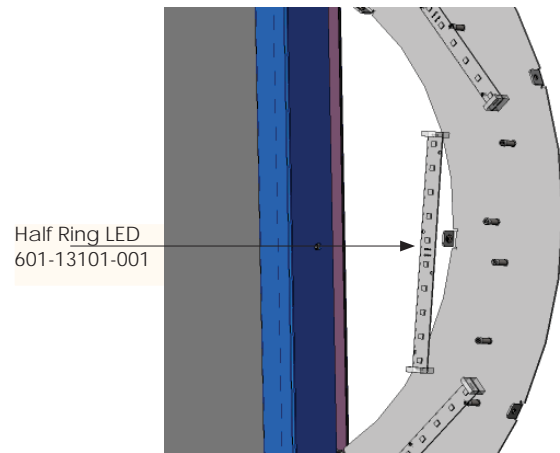

- 
- 4** When replacing, take precautions not to overtighten. Reconnect the harnesses and refit the Outer Ring Cover using the fixings removed in step 1,

## 13-4 FULL HOOP LED LIGHTING

### WARNING

MAKE SURE THAT THE MAIN SUPPLY VOLTAGE TO THE MACHINE IS SWITCHED OFF BEFORE ATTEMPTING TO CARRY OUT THIS WORK

- 1 To remove the FULL HOOP Outer cover, locate and remove the (9) M4x12 SKT BH PAS (029-B00412). Remove (5) from the outer edge and (4) from the inner edge.

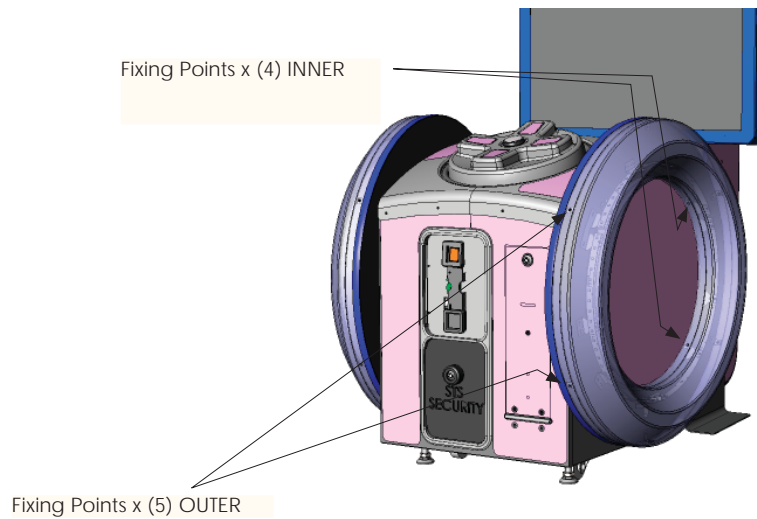

- 2 Carefully remove the COVER SIDE RING and place flat to one side.

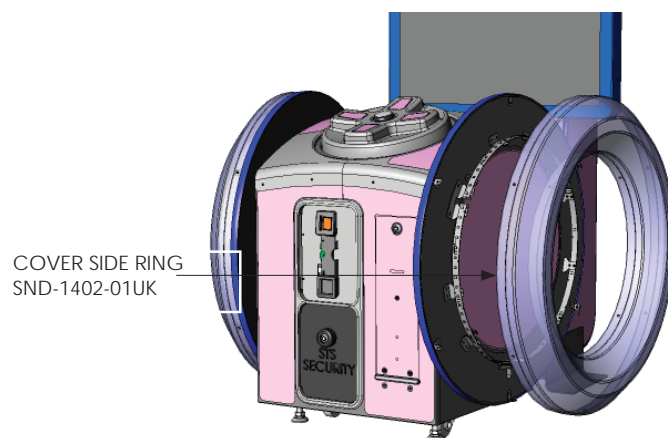

- 3 With the COVER SIDE RING removed, locate the suspect LED Bd to replace and disconnect the connectors at both ends.

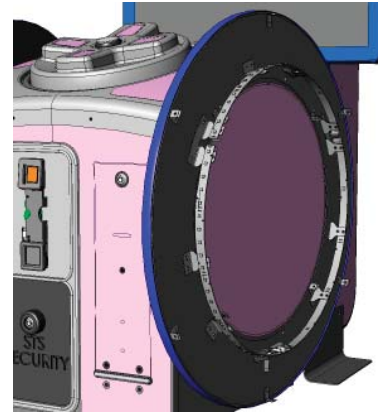

- 4 Once the Cover has been removed and the harness disconnected, remove the (4) M3x16 SKT BH BLK fixings which secure the LED Bd to the metal retaining brackets.

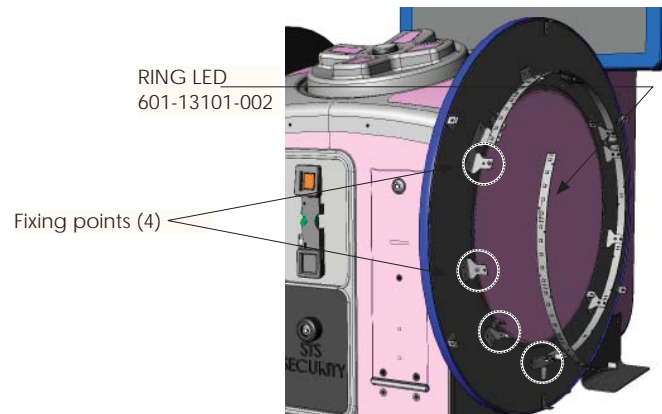

- 5 Replace the suspect LED Bd with one of the same type and secure using the same fixings from Step 4. Reconnect at both ends and replace the COVER RING SIDE. Follow instructions in reverse order.

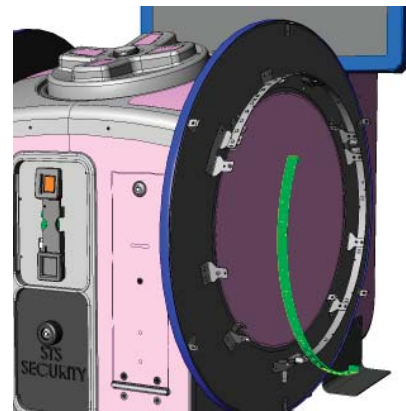

## 14 PERIODIC INSPECTION

The items listed below require periodic check and maintenance to retain the performance of this machine and to ensure safe business operation.

When handling the controller, the player will be in direct contact with it. In order to always allow the player to enjoy the game, be sure to clean it regularly. Also, it is advisable to provide wet tissue, etc. available for player use.

### WARNING

- Every 6 months check to see if power cords are damaged, the plug is securely inserted, dust is accumulated between the socket outlet and the power plug, etc. Using the product with accumulated dust in the interior may cause fire or electric shock.
- Never use a water jet, etc. to clean the inside and outside of the cabinet. If wetness occurs for any reason, do not use the product until it has completely dried.
- Once a year, request the office shown on this manual or the dealer from whom the product was originally purchased to perform the internal cleaning. Using the product with accumulated dust in the interior may cause fire or other accidents.

Note that you are liable for the cost of cleaning the interior parts.

- There is the danger of accidents involving electrical shorts circuits or fire caused by factors such as the deterioration of insulation in electrical and electronic equipment over time. Check that there are no abnormalities such as odors from burning.

14 TABLE 01 PERIODIC INSPECTION TABLE

ITEMS	DESCRIPTION	PERIOD
CABINET	Confirm that adjusters contact floor	Daily
CONTROL PANEL CONTROLLER	Operation inspection	Weekly
	Cover and fixings inspection	Every 1 month
	Switch and lighting inspection	Every 3 months
COIN ACCEPTOR	Acceptance of coins	Daily
	Coin Lamp	Every 3 months
	Cleaning	Every 3 months
HALF HOOP	Lighting	Every 1 month
	Condition	Every 3 months
FULL HOOP	Lighting	Every 1 month
	Confirm settings	Every 3 months
TICKET MECHANISM	Operation	Monthly
	Cleaning	Monthly
	Sensor out	Every 3 months
BILLBOARD	Lighting	Every 3 months
GAME BOARD	Confirm settings	Monthly
POWER CABLES	Inspection, Cleaning	6 months
INTERIOR	Cleaning	Yearly
CABINET SURFACES	Cleaning	As appropriate



### Cleaning the Cabinet Surfaces

When the cabinet surfaces are badly soiled, remove stains with a soft cloth dipped in water or diluted (with water) chemical detergent and squeezed dry. To avoid damaging surface finish, do not use such solvents as thinner, benzine, etc. other than ethyl alcohol, or abrasives, bleaching agent and chemical dustcloth.

Some general-purpose household, kitchen and furniture cleaning products may contain strong solvents that degrade plastic components, coatings, and print. Before using any cleaning product, read the product's cautionary notes carefully and test the product first on a small area that is not highly visible.

### Screen (Cleaning)

The 55" LED Monitor is protected by a safety glass which is mounted in front of the screen. It is important that the screen is cleaned regularly as so not to impair the players experience. It is recommended that the glass is cleaned once a week to keep the viewing area free from marks or dust. When cleaning use a well known branded glass cleaner.

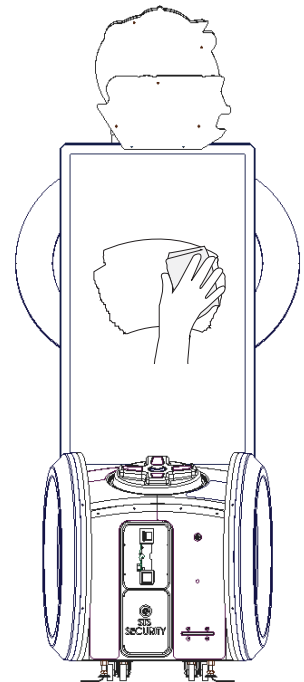

# 15 TROUBLESHOOTING

## 15-1 TROUBLESHOOTING (WHEN NO ERROR MESSAGE IS SHOWN)

**⚠ WARNING**

- In order to prevent electric shock and short circuit, be sure to turn power off before performing work.
- Be careful so as not to damage wirings. Damaged wiring can cause electric shock or short circuit.
- After removing the cause of the functioning of the Circuit Protector, reinstate the Circuit Protector. Depending on the cause of the functioning, using the Circuit Protector as is without removing the cause can cause generation of heat and fire hazard.
- In the event that a problem cannot be resolved by employing the procedures listed in this Manual, be sure to request service from the office shown on this Manual or the dealer from whom the product was originally purchased. Attempts to employ procedures other than those specified in this Manual can cause electrical shock, shorting, or fire.
- In the event of a problem that is not described here, be sure to contact the office shown on this Manual or the dealer from whom the product was originally purchased. Careless attempts at repair can result in electrical shock, shorting, or fire.

If a problem occurs, first check to make sure that the wiring connectors are properly connected.

**15 TABLE 01**

PROBLEM	CAUSE	COUNTERMEASURES
When the main SW is turned ON, the machine is not activated.	The power is not ON.	Firmly insert the plug into the outlet.
	Incorrect power source/voltage.	Make sure that the power supply/voltage are correct.
	The Fuse on the AC Unit has blown due to momentary over current.	After eliminating the cause of overload, replace the specified rating fuse.
	The fuse of the connect board has blown due to momentary over current.	After eliminating the cause of overload, replace the specified rating fuse.

Sound is not emitted.	Sound volume adjustment is not correct	Adjust the Switch Unit's sound adjustment volume.
	Faulty connections for various connectors	Check the connections for the game board, amp, speakers and Volume connectors
	Malfunctioning BD, amp and speaker	Perform Sound Test.
Sounds are emitted and the lamps are lit, but the screen is black.	Faulty connections for the visual signal connector or the monitor power connector	Check the connections for the monitor and game board connectors.
	Faulty LCD Display	See Chapter 11
Colors on the monitor screen are strange.	Faulty connection for the visual signal connector.	Check the visual signal connector connection and make sure it is secured properly.
	Screen adjustment is not appropriate.	Make adjustment appropriately.
The on-screen image sways and/or shrinks.	The power source and voltage are no correct.	Make sure that the power supply and voltage are correct.
Does not accept input from any switch or volume.	Faulty connector connections.	Check the connection for the I/O Board and Cabinet connector.
		Check the power for the I/O Board.
No LED lighting from HOOPS or HALF HOOPS	Faulty connector connections.	Check the connection for the I/O Board and Cabinet connector.
		Check the power for the I/O Board.
	Faulty PSU	Check for Power LED indicator on PSU.
No Ticket output	Faulty connector connections.	Check the connections for the connectors between the I/O Board and Ticket Dispenser.
		No Motor drive
	Motor drives but no Tickets dispensed.	Check feed of tickets within Ticket dispenser.
Game will not start	Faulty connections	Check connections to and from the Controller and I/O Bd. Check Connections at Switch.

## Replacing Fuses

### WARNING

- In case fuse replacements other than those stated in this manual are necessary, contact where you purchased the product from for inquiries regarding this matter.
- In order to prevent an electric shock, be sure to turn power off and unplug from the socket outlet before performing work by touching the internal parts of the product.
- Be careful so as not to damage wirings. Damaged wiring can cause electric shock and short circuit accidents.
- Be sure to use fuses meeting specified rating. Using fuses exceeding the specified rating can cause fire and electric shock accidents.
- After eliminating the cause of the blowing of fuse, replace the fuse. Depending on the cause of fuse blowing, continued use with the fuse as is blown can cause generation of heat and fire hazard.

Fuses are located on the following:

SND-1080UK	Assy AC Unit	(1) 3.15 Time Delay 20mm (1) 3.15 Time Delay 20mm (Spare)
838-14551-02UK	AC Distribution PCB	(2) 6.3A Time Delay 20mm

## 16 GAME BOARD (NuSX)

16

GAME BOARD

### WARNING

- When working with the product, be sure to turn the power off. Working with the power on may cause an electric shock or short circuit.
- Be careful not to damage the wires. Damaged wires may cause an electric shock, short circuit or present a risk of fire.
- Do not use this product with connectors other than those that were connected and used with the game board at the time of shipping. Do not carelessly connect wires to connectors that were not used at the time of shipping, as this may cause overheating, smoke or fire damage.

### CAUTION

In this product, setting changes are made during the test mode. The game board need not be operated. Use the game board, etc. as is with the same setting made at the time of shipment so as not to cause electric shock and malfunctioning.

### IMPORTANT

Static electricity from your body may damage some electronics devices on the IC board. Before handling the IC board, touch a grounded metallic surface so that the static electricity can be discharged.

## 16-1 HANDLING PRECAUTIONS

### WARNING

- To prevent electric shock or IC Board malfunctioning, be sure to turn off the power for the cabinet when installing or removing the IC Board.
- Extraneous matter such as dust on the IC Board can cause the IC Board to generate heat and result in a fire due to short circuit, etc. Ensure the IC Board surfaces are always kept clean.
- Always follow the usage conditions from SEGA as well as the usage conditions for the cabinet you are using for NuSX. Failure to do so may cause an overheating and fire.

### IMPORTANT

- Be sure to connect the IC Board and connectors completely. Insufficient insertion can damage IC Board, etc.
- For the IC Board circuit inspection, only the use of Logic Tester is permitted. The use of ordinary testers is not permitted as these can damage the IC Board.
- Do not subject the IC Board to static electricity when installing the IC Board in the cabinet or when connecting wire harness connectors to the IC Board.
- When soldering buttons, etc. to the wire harnesses, be sure to remove the wire harnesses from the IC Board so as not to subject the IC Board to heat.
- Some parts are the ones designed and manufactured not specifically for this product. The manufacturers may discontinue, or change the specifications of, such general-purpose parts. If this is the case, SEGA cannot repair or replace a failed product whether or not a warranty period has expired.

### IMPORTANT

- It is important that the NuSX Game Bd is cleaned free from dust regularly. If dust accumulates within the NuSX Game bd, the Game bd may malfunction.
- If any components are removed during cleaning be sure to reconnect them in the same manner as they were removed. Ill fitted components may malfunction, become faulty or may possibly cause a fire hazard.
- If you are unsure about refitting components then please contact the point of sale to arrange for a return or replacement NuSX Game Bd.

## 16-2 GAME BOARD (NuSX) - LOCATION

### WARNING

- When returning the game board after making repairs or replacements, make sure that there are no errors in the connection of connectors. Erroneous connections can lead to electrical shock, short circuits or fires.
- When connecting a connector, check the direction carefully. Connectors must be connected in only one direction. If indiscriminate loads are applied in making connections, the connector or its terminal fixtures could be damaged, resulting in electrical shock, short circuits or fires.

The NuSX Game Bd is fitted at the rear of the cabinet and mounted to the inside RH cheek.

- 1** Remove the power from the machine and disconnect the Power lead.
- 2** Remove the (2) fixings from the upper corners of the door. Unlock and remove the door using the key (supplied)
- 3** The NuSX is located directly inside mounted to the inside wall of the cabinet.

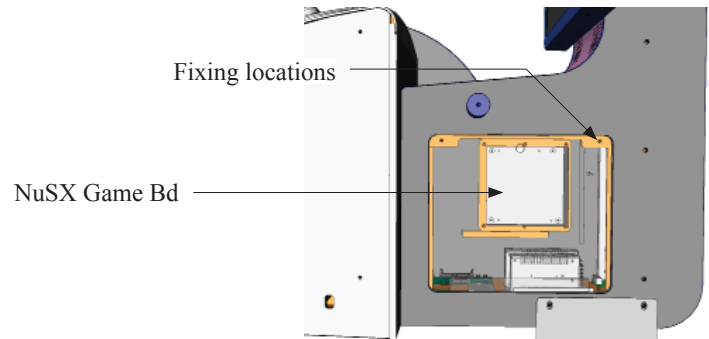

- 4** Disconnect the Video, Audio, USB and COM 2 harnesses from the NuSX Game Bd..

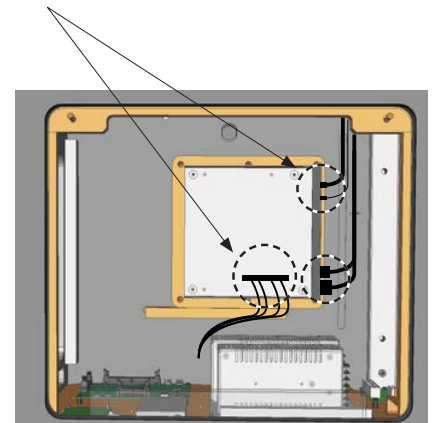

- 5** Locate the (6) M4 fixings positioned on the outer edges of the wooden mount. Unscrew and remove. The Game board can now be removed from the cabinet.

16

GAME BOARD

## 16-3 NuSX CLEANING

### **STOP** IMPORTANT

- If either ERROR 0090 or ERROR0091 are displayed then the Game bd must be cleaned and made free from dust particles. These ERRORS have been put in place to prevent the Game bd from overheating in not cleaned on a regularly basis.

It is important that once a year the CPU cooling fan is cleaned and made free from dust. Please refer to section 16-2 for the NuSX removal procedure.

**1** Refer to section 16-2 of this manual for removal of the NuSX Game Bd procedure.

**2** Use an aerosol air spray to remove the dust which has accumulated in and around the CPU cooler. Once completed use a small vacuum cleaner to suck up any loose dust particles and to clean out the Cooler fan. The fan blade will rotate when using a Vacuum cleaner to clean it. Using your finger, press down lightly upon the centre of the fan to prevent it from rotating.

### **STOP** IMPORTANT

**Please be aware as not to damage the CPU COOLER blades or housing. These parts are delicate and can damage easily. Take care when cleaning.**

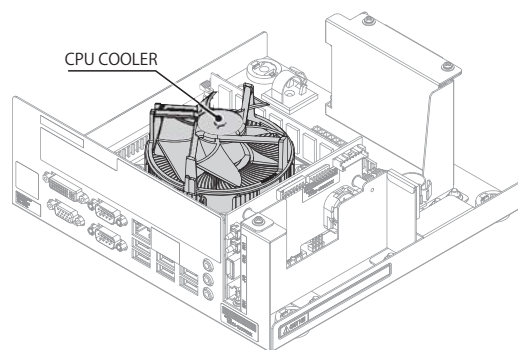

**3** Also clean any accumulated dust from within the CASE using an aerosol air cleaner. Take care not to damage parts.

**4** By referring to section 16-2 and following it in reverse order, please attach the NuSX to the cabinet.



## 16-4 REPLACING THE LITHIUM BATTERY

16

GAME BOARD

### WARNING

- All maintenance must be performed by a qualified technical. Work carried out by any other than a qualified technician may cause the product to malfunction, overheat or even an electric shock.
- Please remove power before commencing any work. Failure to remove power may cause an electric shock, short circuit or fire hazard.
- Take care when working within the NuSX case as not to damage the IC Board or its component and harnessing. Damaging any of these parts may cause and electric shock, short circuit or fire hazard.
- Please adhere to the following when handling batteries:-
  - Never try to charge or apply any voltage to the battery with the purpose in which to charge.
  - Never try to disassemble the battery.
  - Do not apply heat to the battery or store it near a heat source.
  - Do not dispose of a battery within a fire or try to incinerate.
  - Do not dispose of batteries along with normal household waste.
- Please do not carry out any repairs/maintenance not described within this manual. Carrying out repairs/maintenance outside this manual may result in electric shock, short circuit or fire hazard.
- When Power is first applied after maintenance, please be aware of the state of the CPU and other electronic components. If anything outside the normal operation occurs be ready to remove power.
- Please take care when reconnect harnesses. Make sure connectors are firmly connected. If damage occurs during reconnecting then please contact your local SEGA office for replacement.

## WARNING

- Make sure you do not damage the printed board and wires. Such damage can lead to electric shock, short circuit and fire hazard.
- To prevent overheating, explosion, or fire:
  - Do not recharge, disassemble, heat, incinerate, or short the battery.
  - Do not allow the battery to come into direct contact with metallic objects or other batteries.
  - To preserve the battery, wrap it in tape or other insulating material.
- Follow local regulations when disposing of the battery. Improper disposal can damage the environment.
- Even the site maintenance personnel or other qualified professionals must not perform replacement operations for parts not described in this manual. In the event that such work is required either contact the office listed in this manual or first confirm the procedure with the place or office of purchase. Failure to do so may lead to electric shock or short circuit.
- Do not turn on the power with current carrying parts exposed. Doing so could result in electric shock or short circuit.

## CAUTION

To avoid risk of malfunction and damage:

- Make sure the positive and negative ends are aligned correctly.
- Use only batteries approved for use with this unit.

## IMPORTANT

- The batteries in NuSX can be used for approximately 5 years of standard usage. If the battery appears to require replacement sooner than 5 years it is more likely that an error has occurred with some other part of the board. Rather than exchanging the battery requesting repair of the board itself may be more appropriate.
- Static electricity from your body may damage some electronics devices on the IC board. Before handling the IC board, touch a grounded metallic surface so that the static electricity can be discharged.

## AM EXPANSION BOARD

Only replace the battery when prompted by the displayed error. Do not perform this task otherwise. The battery within the AM Expansion Board has a life span of approximately 5 years of normal use. After 5 years normal operation the AM Expansion Bd may no longer be able to save the backup data. Please replace the battery within this time.

If within the 5 years of normal operation the battery needs replacing, please contact your local Sega Service centre as it may be considered that some abnormalities may have occurred within the Game Bd.

16

GAME BOARD

**1** Please refer to section 16-2 of this manual for instructions on safely removing the NuSX Bd from the cabinet.

**2** To remove the Expansion Bd, unscrew the single M3 machine screw and the (2) M4 flange nuts.

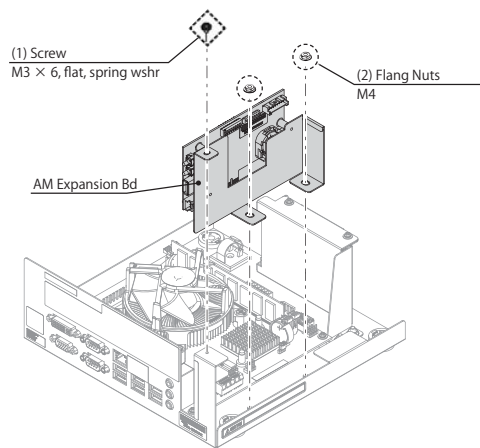

**3** Once the Expansion Bd is removed from the NuSX. Unscrew and remove the (3) M3x6 Machine screws which secure the Expansion Bd to the Expansion Bd Brkt.

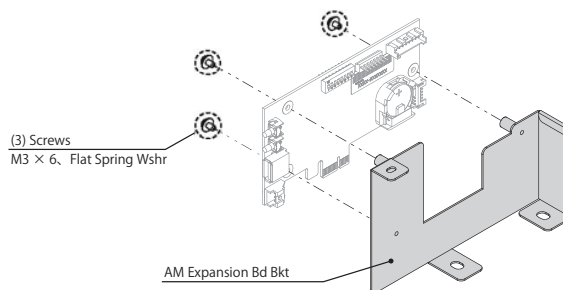

- 
- 4** To remove the battery from the Expansion Bd, using your finger nad thumb, lift up the battery to enable you to grasp it from the top. Take note of the battery orientation. The (+) positive is facing outside.

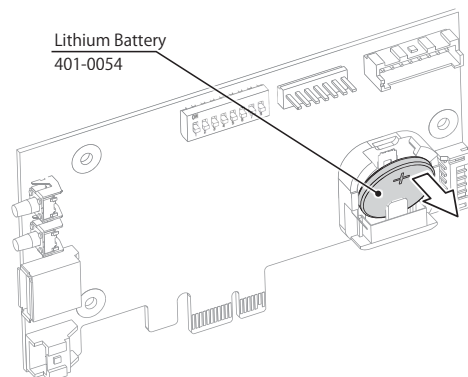

- 
- 5** After the new battery has been replaced, please refer to these instructions and apply them in reverse order to reassemble.

## MAIN BOARD

**1** Please refer to section 16-2 of this manual for instructions on safely removing the NuSX Bd from the cabinet.

**2** Remove the Expansion Bd, unscrew the single M3 machine screw and the (2) M4 flange nuts.

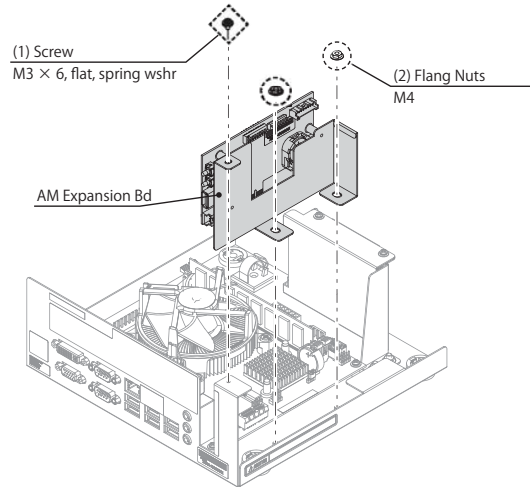

**3** To replace the battery on the MAIN BD. Pull up the lock on the battery holder and remove the Lithium battery. It is important that the Lithium battery is replaced immediately. If a time of 100 seconds or more lapses then it is possible that a CMOS Checksum error may occur. You may receive an error in the display. If it occurs then please contact your local Sega Service center as described within this manual.

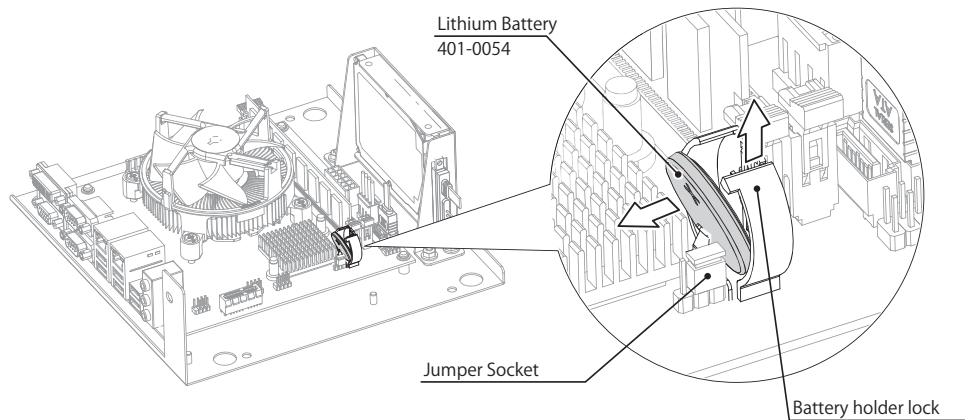

**4** To reassemble, follow these instructions in reverse order.

## 16-5 NuSX CONNECTIONS

The NuSX Game Bd has various connections which are required by this game and therefore need to be connected for the game to function correctly.

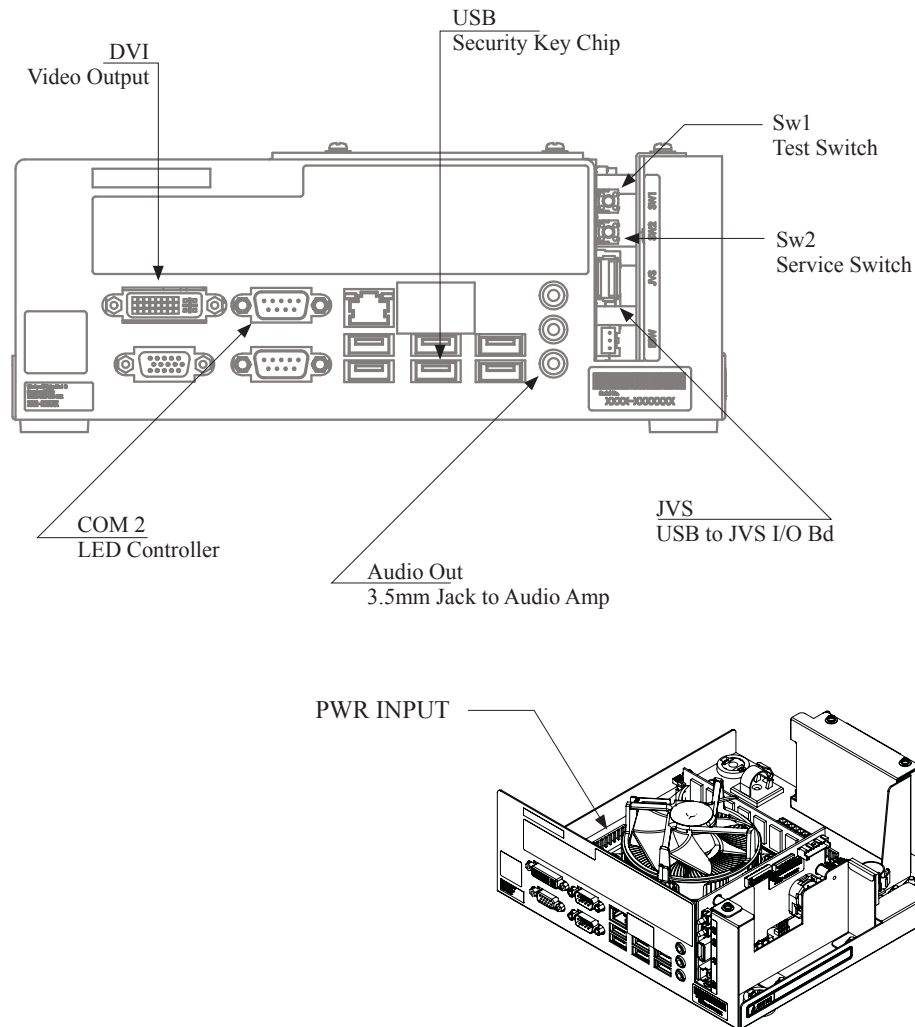

Any other connection made to the NuSX which are not highlighted in this section should not be made. DO NOT connect phone chargers or any other auxiliary electronic item into the unused USB posts. Connection items such as chargers will cause an over current power demand which can result in malfunction or even fire hazard.

## 16-6 ERROR CODES

16

GAME BOARD

### WARNING

- If an error is displayed, have the site maintenance personnel or other qualified individuals resolve it. If someone without specialized or technical knowledge attempts to rectify the problem, electric shock, short circuits or fire may result. If there is no site maintenance personnel or other qualified individuals available, turn the power off immediately, and contact the office listed in this manual or the point-of-purchase for this product.
- If a problem not described in this manual occurs, or the resolution to a problem described in this manual is not effective, do not make further attempts to resolve the problem yourself. Immediately turn off the power and contact the office listed in this manual or the point-of-purchase for this product. Any unguided attempts to solve such problems may lead to a serious accident.

### IMPORTANT

- Static electricity from your body may damage some electronics devices on the IC board. Before handling the IC board, touch a grounded metallic surface so that the static electricity can be discharged.
- Do not repeatedly turn the power on/off in a short period of time. Doing so may result in breakdown or parts damage.
- If an error number or message not listed below appears, cease using the product immediately and contact the office listed in this manual or the point-of-purchase for this product.
- The error display may be different depending on the OS version.

The NuSX is equipped to display various errors on-screen to help solve any problems. If an error is displayed, the game cannot be used. Use the following table of causes and countermeasures to solve the problem. If the problem cannot be resolved, contact the office listed in the manual or the Point-of-purchase.

0001	DISPLAY	Error 0001 Keychip Not Found
	CAUSE	There is no key chip, or the key chip is not connected correctly.
	COUNTERMEASURES	Check that the key chip is connected correctly. [See 2-2 (P. 2).]
0002	DISPLAY	Error 0002 Keychip Not Available
	CAUSE	The key chip is not supported.
	COUNTERMEASURES	Check the key chip and installation media (such as the DVD) combination.
0004	DISPLAY	Error 0004 Game Program Not Acceptable
	CAUSE	The key chip is not supported.
	COUNTERMEASURES	Check that the key chip from a different system is not inserted.
0008	DISPLAY	Error 0008 Keychip Access Failed
	CAUSE	The key chip could not be accessed.
	COUNTERMEASURES	Turn the power off and reinsert the key chip, and then restart the Nu.
0010	DISPLAY	Error 0010 Unexpected Game Program Failure
	CAUSE	The game program crashed due to an unexpected error.
	COUNTERMEASURES	Turn the power off and restart the Nu.
0020	DISPLAY	Error 0020 AMEX Not Found
	CAUSE	The AM expansion board is not recognized.
	COUNTERMEASURES	Turn the power off and restart the Nu.
0021	DISPLAY	Error 0021 Main board Malfunctioning
	CAUSE	The main board does not recognize itself.
	COUNTERMEASURES	Turn the power off and restart the Nu.
0022	DISPLAY	Error 0022 Game Program Not Found on Storage Device
	CAUSE	There is no game program on the storage device.
	COUNTERMEASURES	Use the installation media (such as the DVD) to reinstall the game program.
0023 0024 0025 0026	DISPLAY	Error 0023 (0024, 0025, 0026) Main board Malfunctioning
	CAUSE	Failed to access the main board.
	COUNTERMEASURES	Turn the power off and restart the Nu.



0027	DISPLAY	Error 0027 Low Battery
	CAUSE	The button battery for the AM expansion board does not have enough charge.
	COUNTERMEASURES	Replace the button battery on the AM expansion board. [See 6-1 (P. 43).]
0028 0029	DISPLAY	Error 0028 (0029) Main board Malfunctioning
	CAUSE	Failed to access the main board.
	COUNTERMEASURES	Turn the power off and restart the Nu.
0041	DISPLAY	Error 0041 Game Program Not Found on Install Media
	CAUSE	There is no game program on the installation media.
	COUNTERMEASURES	Check that the game program, place on the installation media (such as the DVD), and the key chip correspond to each other.
0042	DISPLAY	Error 0042 Game Program Not Found on Install Media
	CAUSE	Some part of the game program is missing.
	COUNTERMEASURES	Check how the game program was installed.
0049	DISPLAY	Error 0049 Install Media Access Failed
	CAUSE	Failed to access the installation media.
	COUNTERMEASURES	Check that the installation media (such as the DVD) is not scratched, damaged or dirty. Check that the DVD drive is connected correctly.
0052	DISPLAY	Error 0052 Install Media Access Failed
	CAUSE	Failed to access the installation media.
	COUNTERMEASURES	Check that the installation media (such as the DVD) is not scratched, damaged or dirty. Check that the DVD drive is connected correctly.
0055	DISPLAY	Error 0055 Game Program Verify Error
	CAUSE	The installed game program is not working correctly.
	COUNTERMEASURES	Use the installation media (such as the DVD) to reinstall the game program.
0064	DISPLAY	Error 0064 Game Program Not Found on Server
	CAUSE	No game program on the LAN install server.
	COUNTERMEASURES	Check that the game program, place on the LAN install server, and the key chip correspond to each other.

0066	DISPLAY	Error 0066 Game Program Verify Error
	CAUSE	The installed game program is not working correctly.
	COUNTERMEASURES	Use the installation media (such as the DVD) to reinstall the game program.
0081	DISPLAY	Error 0081 Invalid Storage Format
	CAUSE	The main storage (SSD) format is wrong.
	COUNTERMEASURES	Contact the office listed in this manual or the point-of-purchase for this product.
0082	DISPLAY	Error 0082 Game Program Access Failed
	CAUSE	The main storage (SSD) cannot be recognized.
	COUNTERMEASURES	Use the installation media (such as the DVD) to reinstall the game program.
0083	DISPLAY	Error 0083 Storage Device Not Acceptable
	CAUSE	The main storage (SSD) does not have enough space.
	COUNTERMEASURES	Check that the sub storage (HDD) is connected correctly.
0084	DISPLAY	Error 0084 Storage Device Malfunctioning
	CAUSE	The main storage (SSD) may be broken.
	COUNTERMEASURES	Turn the power off and restart the Nu.
0085	DISPLAY	Error 0085 Invalid Storage Format
	CAUSE	The main storage (SSD) format is wrong.
	COUNTERMEASURES	Contact the office listed in this manual or the point-of-purchase for this product.
0086	DISPLAY	Error 0086 Invalid Storage Format
	CAUSE	The sub storage (HDD) format is wrong.
	COUNTERMEASURES	Run the FORMAT SUB STORAGE command from SYSTEM TEST MODE. [See 3-2 (P. 10).]
0087	DISPLAY	Error 0087 Storage Device Malfunctioning
	CAUSE	The sub storage (HDD) may be broken.
	COUNTERMEASURES	Turn the power off and restart the Nu.

0088	DISPLAY	Error 0088 System Program Verify Error
	CAUSE	The installed system program is not working correctly.
	COUNTERMEASURES	Use the installation media (such as the DVD) to reinstall the game program.
0090	DISPLAY	Error 0090 High CPU Temperature
	CAUSE	The CPU temperature is high.
	COUNTERMEASURES	Clean the Nu and around the Nu installation point. Also, check whether the air flow outlets on the Nu are blocked. [See Chapter 5 (P. 39).]
0091	DISPLAY	Error 0091 Too High CPU Temperature
	CAUSE	The CPU temperature is high.
	COUNTERMEASURES	Clean the Nu and around the Nu installation point. Also, check whether the air flow outlets on the Nu are blocked. [See Chapter 5 (P. 39).]
0901	DISPLAY	Error 0901 Wrong Platform
	CAUSE	The game program is not supported by the Nu.
	COUNTERMEASURES	Check the game program manual. Check whether the combination of the game program and the Nu is correct.
0902	DISPLAY	Error 0902 Wrong System Program
	CAUSE	It was started up with an unsupported system program. The Nu system program must be updated.
	COUNTERMEASURES	Check how the game program was installed.
0903	DISPLAY	Error 0903 Wrong Region
	CAUSE	Combination for destination is incorrect.
	COUNTERMEASURES	Check the combination for the destination that relates to the Nu, key chip and installation media (such as the DVD).
0904	DISPLAY	Error 0904 Wrong Platform
	CAUSE	The installed system program is not working correctly.
	COUNTERMEASURES	Use the installation media (such as the DVD) to reinstall the game program.
0905	DISPLAY	Error 0905 Graphic Function Not Found
	CAUSE	The game program does not support the graphics function.
	COUNTERMEASURES	Contact the office listed in this manual or the point-of-purchase for this product.

0906	DISPLAY	Error 0906 Sound Function Not found
	CAUSE	The Nu sound function cannot be recognized.
	COUNTERMEASURES	Contact the office listed in this manual or the point-of-purchase for this product.
0907	DISPLAY	Error 0907 Not Enough System Memory
	CAUSE	The game program does not have enough memory.
	COUNTERMEASURES	Contact the office listed in this manual or the point-of-purchase for this product.
0908	DISPLAY	Error 0908 Not Enough SRAM
	CAUSE	The game program does not have enough SRAM.
	COUNTERMEASURES	Contact the office listed in this manual or the point-of-purchase for this product.
0909	DISPLAY	Error 0909 Not Enough Storage Device
	CAUSE	The game program does not have enough storage.
	COUNTERMEASURES	Contact the office listed in this manual or the point-of-purchase for this product.
0910	DISPLAY	Error 0910 Wrong Resolution Setting
	CAUSE	The game program does not support the current resolution settings.
	COUNTERMEASURES	Change the DIP SW to the correct settings and restart the Nu. [See 2-2 (P. 2).]
0911	DISPLAY	Error 0911 Wrong Horizontal/Vertical Setting
	CAUSE	The monitor horizontal/vertical settings are incorrect.
	COUNTERMEASURES	Change the DIP SW to the correct settings and restart the Nu. [See 2-2 (P. 2).]
0912	DISPLAY	Error 0912 Unexpected Game Program Failure
	CAUSE	The graphics board was unable to continue rendering.
	COUNTERMEASURES	Turn the power off and restart the Nu.
0914	DISPLAY	Error 0914 Not Enough Function
	CAUSE	There are not enough functions and boards required for the game program.
	COUNTERMEASURES	Contact the office listed in this manual or the point-of-purchase for this product.

0915	DISPLAY	Error 0915 Wrong Storage Device
	CAUSE	The game program does not have enough storage.
	COUNTERMEASURES	Run the FORMAT SUB STORAGE command from SYSTEM TEST MODE. [See 3-2 (P. 10).]
0916	DISPLAY	Error 0916 Wrong Storage Device
	CAUSE	The game program does not support the sub storage (HDD).
	COUNTERMEASURES	Contact the office listed in this manual or the point-of-purchase for this product.
0949	DISPLAY	Error 0949 Keychip Not Found
	CAUSE	There is no key chip or there is a defect with its connection.
	COUNTERMEASURES	Check that the key chip is connected correctly.
6401	DISPLAY	Error 6401 JVS I/O board is not connected to main board
	CAUSE	(1) The JVS I/O board is not connected. (2) Unreliable connection between the Nu and the JVS I/O board.
	COUNTERMEASURES	(1) Connect the JVS I/O board to the Nu. Check that the power cable is connected to the JVS I/O board. (2) Reconnect or replace the JVS cable that connects the JVS I/O board to the Nu.
6402	DISPLAY	Error 6402 JVS I/O board does not fulfill the game spec
	CAUSE	The correct JVS I/O board is not connected.
	COUNTERMEASURES	Use an JVS I/O board that provides the proper input/output for the game program.
8001	DISPLAY	Error 8001 Network address error (DHCP)
	CAUSE	The network connection settings could not be initialized.
	COUNTERMEASURES	Check the network connection and follow the startup procedures to restart the Nu.
8002	DISPLAY	Error 8002 Network setting error (SYSTEM)
	CAUSE	The SYSTEM TEST MODE NETWORK SETTING is incorrect.
	COUNTERMEASURES	Check the NETWORK SETTING. [See 3-8 (P. 25).]

8103	<b>DISPLAY</b>	Error 8103 ALL.Net System error (TIMEOUT)
	<b>CAUSE</b>	A connection could not be established with ALL.Net.
	<b>COUNTERMEASURES</b>	Check the Nu network connection, the in-store network connection and the connection between the ALL.Net router and the network cable, and then follow the startup procedures to restart the Nu. [See 3-8 (P. 25).] If the error persists, check the maintenance information.

8106	<b>DISPLAY</b>	Error 8106 ALL.Net System Caution
	<b>CAUSE</b>	A connection could not be established with ALL.Net.
	<b>COUNTERMEASURES</b>	Check the Nu network connection, the in-store network connection and the connection between the ALL.Net router and the network cable, and then follow the startup procedures to restart the Nu. [See 3-8 (P. 25).] If the error persists, check the maintenance information.

8111	<b>DISPLAY</b>	Error 8111 ALL.Net System error (REG)
	<b>CAUSE</b>	ALL.Net registration could not be confirmed.
	<b>COUNTERMEASURES</b>	Check to make sure ALL.Net registration (the agreement) has been successfully completed.

8113	<b>DISPLAY</b>	Error 8113 ALL.Net System error (MODE)
	<b>CAUSE</b>	The ALL.Net settings could not be confirmed.
	<b>COUNTERMEASURES</b>	Contact the office listed in this manual or the point-of-purchase for this product.

8114	<b>DISPLAY</b>	Error 8114 ALL.Net System error (RTC)
	<b>CAUSE</b>	A connection could not be established with ALL.Net.
	<b>COUNTERMEASURES</b>	Check the Nu network connection, the in-store network connection and the connection between the ALL.Net router and the network cable, and then follow the startup procedures to restart the Nu. [See 3-8 (P. 25).] If the error persists, check the maintenance information.

8201	<b>DISPLAY</b>	Error 8201 ALL.Net System error (TIMEOUT)
	<b>CAUSE</b>	A connection could not be established with ALL.Net.
	<b>COUNTERMEASURES</b>	Check the Nu network connection, the in-store network connection and the connection between the ALL.Net router and the network cable, and then follow the startup procedures to restart the Nu. [See 3-8 (P. 25).] If the error persists, check the maintenance information.

8202	<b>DISPLAY</b>	Error 8202 ALL.Net System error (REG)
	<b>CAUSE</b>	ALL.Net registration could not be confirmed.
	<b>COUNTERMEASURES</b>	Check to make sure ALL.Net registration (the agreement) has been successfully completed.

8301	<b>DISPLAY</b>	Error 8301 Network error (GAME-LAN)
	<b>CAUSE</b>	The connection with the devices that make up this game could not be confirmed.
	<b>COUNTERMEASURES</b>	Check the network connection and follow the startup procedures to restart the Nu.
8302	<b>DISPLAY</b>	Error 8302 Maintenance time (GAME)
	<b>CAUSE</b>	Currently the server is undergoing maintenance.
	<b>COUNTERMEASURES</b>	Wait until server maintenance is complete.
8303	<b>DISPLAY</b>	Error 8303 Network error (GAME)
	<b>CAUSE</b>	A connection could not be established with ALL.Net.
	<b>COUNTERMEASURES</b>	Check the Nu network connection, the in-store network connection and the connection between the ALL.Net router and the network cable, and then follow the startup procedures to restart the Nu. [See 3-8 (P. 25).] If the error persists, check the maintenance information.
8304	<b>DISPLAY</b>	Error 8304 Network failed (GAME)
	<b>CAUSE</b>	Unrecoverable network failure occurred.
	<b>COUNTERMEASURES</b>	Check the Nu network connection, the in-store network connection and the connection between the ALL.Net router and the network cable, and then follow the startup procedures to restart the Nu. [See 3-8 (P. 25).] If the error persists, check the maintenance information.



# 17 DESIGN RELATED PARTS

For the warning display stickers, refer to Section 1.





# 18 PARTS LIST

## ASSY TOP SONIC DASH STRUCTURE

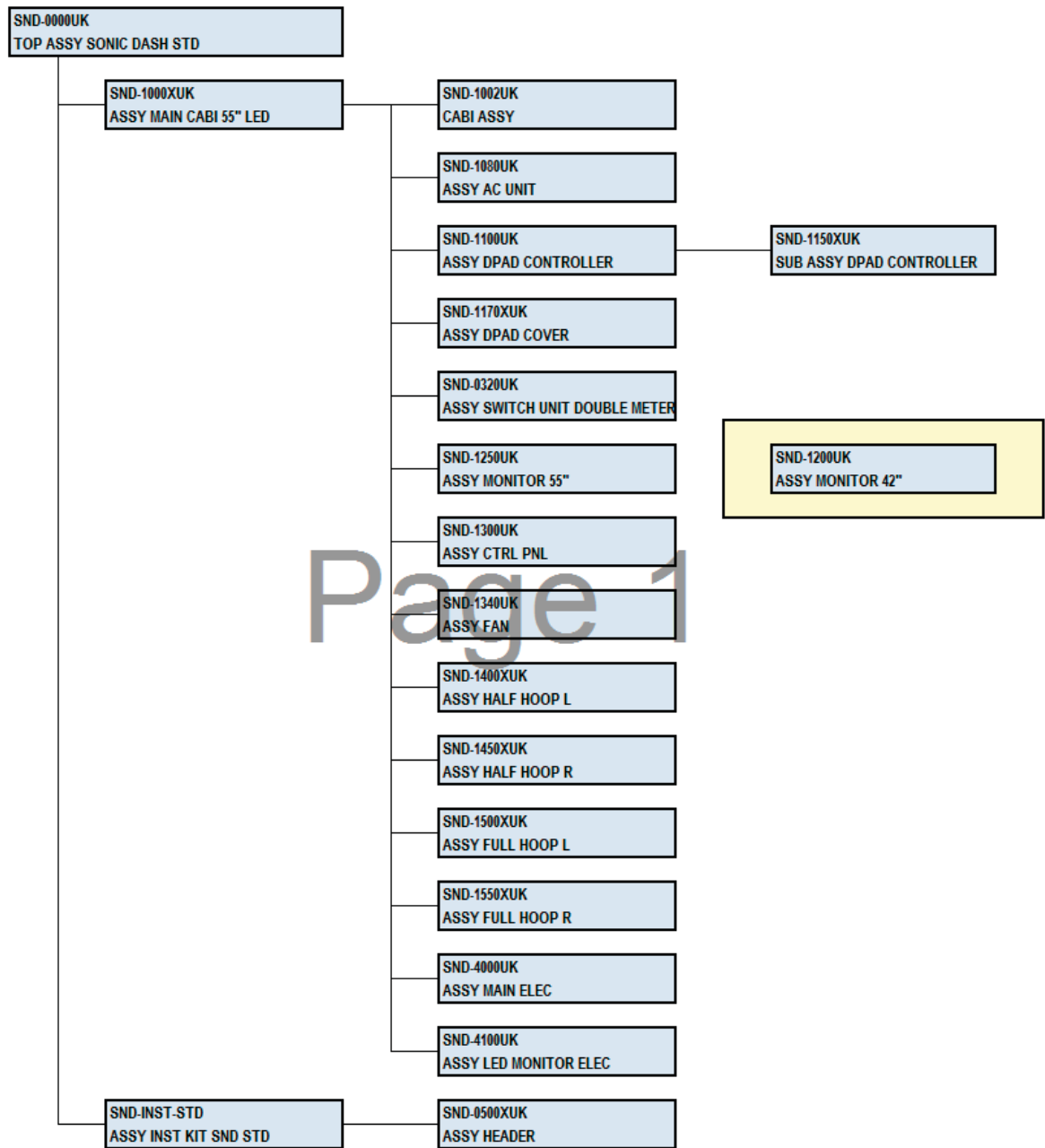

Page 1

① ASSY TOP SONIC DASH (SND-0000UK)

(D-1/1)

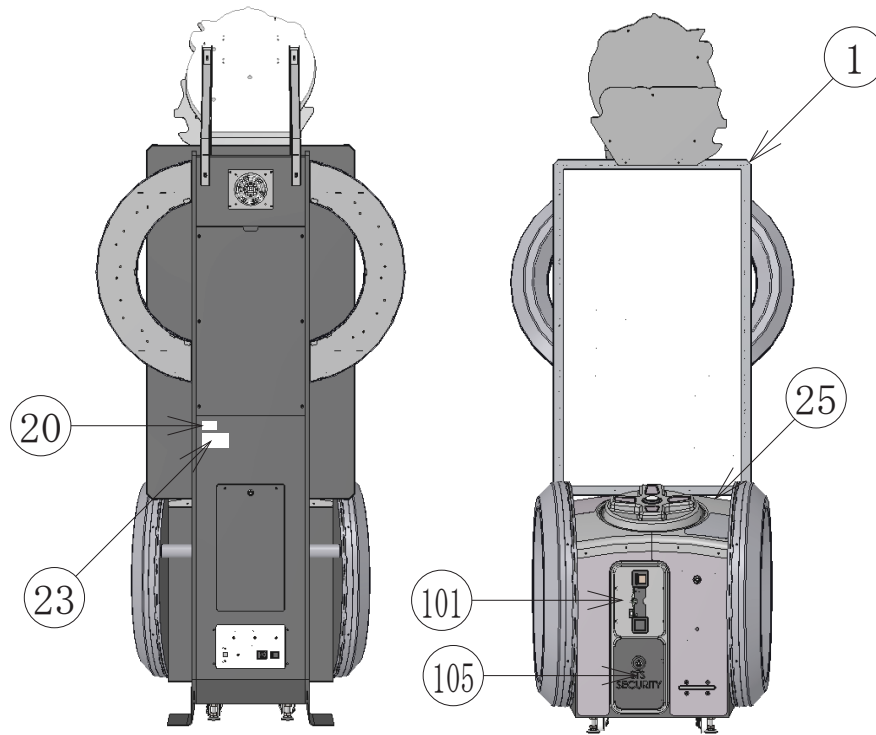

ITEM	PART NUMBER	DESCRIPTION	QTY
*1	SND-1000XUK	ASSY MAIN CABI 55" LED	1
*20	421-7988-91UK	STICKER SERIAL NUMBER UK	2
*21	440-WS0100UK	LABEL WARNING FORK HERE	4
*22	440-DS0010UK	LABEL DANGER HI VOLT	5
*23	LB1046	LABEL TESTED FOR ELEC. SAFETY	1
*24	LB1130	LABEL WEEE WHEELIE BIN	1
*25	440-CS0186-01UK	STICKER CAUTION EPILEPSY	2
*26	440-CS0010UK	LABEL CAUTION GENERIC	2
*101	220-5374-01	DOOR DFMD W/FR&LOCK C120 UNIV	1
*102	220-5575UK	LOCK (J9117) KEY TO LIKE 22MM W CAM	1
*103	OS1247	ALUMINIUM STICKY CLIP ASK-3	3
*105	220-5727-01B	DOOR CASH H.S. STS	1
*401	SND-INST-STD	ASSY INST KIT SND STD	1
*410	PK0502	PALLET SND STD	1
*411	PK0503	SHRINK WRAP SND STD	1

② ASSY SW UNIT DOUBLE METER (SND-0302UK)

(D-1/1)

18 PARTS LIST

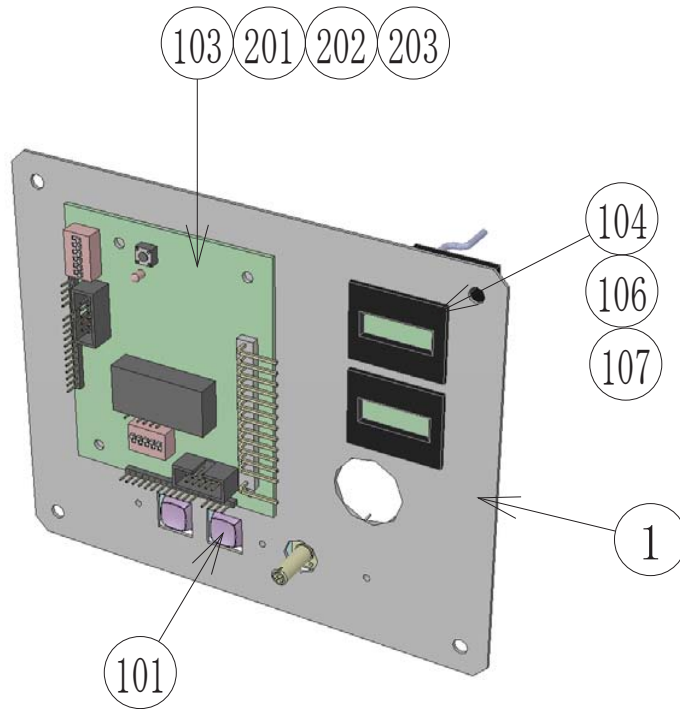

ITEM	PART NUMBER	DESCRIPTION	QTY
***1	SSR-0321UK	SW BRKT DOUBLE METER	1
***2	LB1152	STICKER VTS	1
***101	838-14548-01AUK	SW & VOL CTL BD	1
***102	280-L00706-PM	STANDOFF 6.4MM HOLE PM	4
***103	EP1380-01	CREDIT BOARD EXCEL	1
***104	220-5643UK	COIN METER SMALL 12V	2
***106	601-6231-B095	EDGE TRIM NEW TYPE 0.91t	0.1
***107	OS1098	CRIMP BELL END SMALL	4
***108	601-0460	CABLE TIE NYLON 100MM	2
***201	020-000308-0B	M3X8 SKT CAP BLACK	3
***202	060-F00300-0B	M3 WSHR FORM A FLT BLACK	3
***203	060-S00300-0B	SPR WASHR BLK M3	3
***301	SND-60006UK	WH COIN HANDLING	1

### ③ ASSY HEADER (SND-0500UK)

(D-1/1)

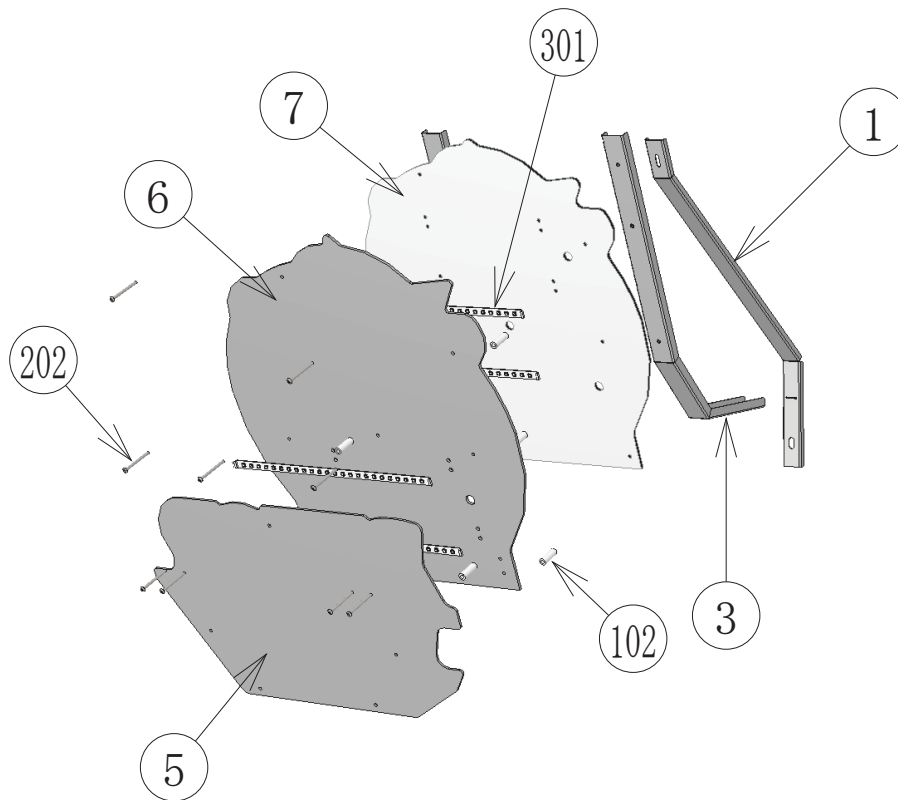

ITEM	PART NUMBER	DESCRIPTION	QTY
***1	SND-0511XUK	BRKT SECURE HEADER REAR SUPP	2
***3	SND-0513XUK	BRKT SECURE HEADER REAR	2
***5	SND-0505UK	PNL HEADER FRONT	1
***6	SND-0506UK	PNL HEADER REAR	1
***7	SND-0517XUK	PNL HEADER BACKBOARD	1
***102	280-L01030-0S	STANDOFF 10OD 5.2ID 30L	9
***103	601-0460	CABLE TIE NYLON 100MM	11
***201	050-F00400	M4 NUT FLG SER PAS	7
***202	008-B00450	M4X50 TMP BH PAS	9
***203	068-441614	M4 WSHR 16OD FLT PAS	5
***204	029-B00412	M4X12 SKT BH PAS	2
***301	SND-6001UK	ASSY LED RIGID 12V WHT 320mm	1

④ ASSY MAIN CABI (SND-1000UK)

(D-1/3)

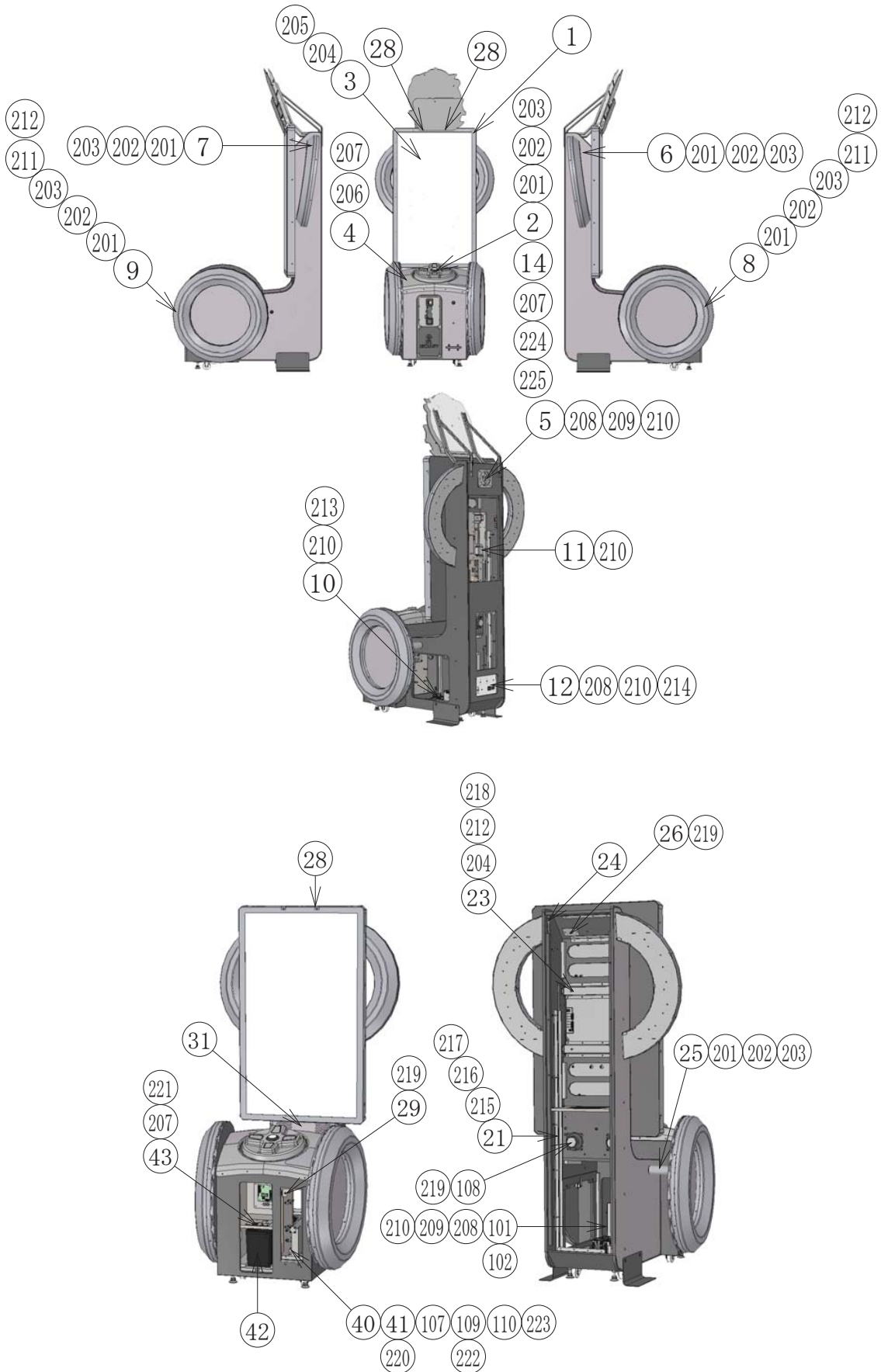

#### ④ ASSY MAIN CABI (SND-1000UK)

(D-2/3)

ITEM	PART NUMBER	DESCRIPTION	QTY
**1	SND-1002UK	ASSY CABINET	1
**2	SND-1100UK	ASSY DPAD CONTROLLER	1
**3	SND-1250UK	ASSY MONITOR 55"	1
**4	SND-1300UK	ASSY CTRL PNL	1
**5	SND-1340UK	ASSY FAN	1
**6	SND-1400XUK	ASSY HALF HOOP L	1
**7	SND-1450XUK	ASSY HALF HOOP R	1
**8	SND-1500XUK	ASSY FULL HOOP L	1
**9	SND-1550XUK	ASSY FULL HOOP R	1
**10	SND-4000UK	ASSY MAIN ELEC	1
**11	SND-4100UK	ASSY LED MONITOR ELEC	1
**12	SND-1080UK	ASSY AC UNIT	1
**13	SND-0320UK	ASSY SWITCH UNIT DOUBLE METER	1
**14	SND-1170XUK	ASSY DPAD COVER	1
**21	SND-1003UK	BRKT CHANNEL CHEEK	2
**23	SND-1005UK	BRKT MON SUPP CROSS BEAM	2
**24	SND-1006UK	PLATE SUPPORT HALF HOOP	2
**25	SND-1007UK	SPACER FULL HOOP SUPP	2
**26	SND-1008XUK	PLATE BB LIGHT MTG	1
**28	SND-0512XUK	BRKT SECURE HEADER MON	2
**29	SND-1011UK	BRKT MTG TICKET RELEASE BTN	1
**31	SND-1013UK	SPEAKER COVER	1
**33	SND-1015UK	STICKER CHEEK L	1
**34	SND-1016UK	STICKER CHEEK R	1
**35	SND-1017UK	STICKER FRONT L	1
**36	SND-1018UK	STICKER FRONT R	1
**40	PG-1106UK	HOLDER TICKET	1
**41	PG-1107UK	BRKT RETAIN TICKET HOLDER	1
**42	PP1087	BOX CASH FOR MINI DOOR	1
**43	DUT-0302UK	COIN PATH PLATE	1
**101	848-1001D-02	ASSY NUSX W HDD EXP	1
**102	610-0890-007BG	KEY CHIP NUSX SONIC DR	1
**107	220-0001-01UK	TICKET VEND UNIT TD-963CR	1
**108	130-010-04020	SPKR 4OHM 20W FR 10 HM 4898	2
**109	838-0015UK	TICKET INTERFACE BOARD	1
**110	EP1820	SW MICRO LEVER RS	1
**112	280-A01264-WX	ROUTER TWIST D12 SO6.4 WOOD X	25
**113	280-A02064-WX	ROUTER TWIST D20 SO6.4 WOOD X	2

## ④ ASSY MAIN CABI (SND-1000UK)

(D-3/3)

**201	029-B00840-0B	M8X40 SKT BH BLK	12
**202	060-S00800-0B	M8 WSHR SPR BLK	12
**203	068-852216-0B	M8 WSHR 22OD FLT BLK	24
**204	068-652016-0B	M6 WSHR 20OD FLT BLK	12
**205	050-F00600	M6 NUT FLG SER PAS	6
**206	029-B00416	M4X16 SKT BH PAS	8
**207	068-441614	M4 WSHR 16OD FLT PAS	19
**208	029-B00425-0B	M4X25 SKT BH BLK	32
**209	060-S00400-0B	M4 WSHR SPR BLK	13
**210	068-441614-0B	M4 WSHR 16OD FLT BLK	36
**211	030-000650	M6X50 BLT PAS	8
**212	060-S00600	M6 WSHR SPR PAS	16
**213	008-B00450	M4X50 TMP BH PAS	4
**214	050-F00400	M4 NUT FLG SER PAS	4
**215	020-F00830-0B	M8X30 SKT CSK BLK	10
**216	050-F00800	M8 NUT FLG SER PAS	10
**217	029-B00825-0B	M8X25 SKT BH BLK	2
**218	029-B00612	M6X12 SKT BH PAS	8
**219	012-P03512-FB	N6x1/2" S/TAP FLG BLK	12
**220	020-F00625-0Z	M6X25 SKT CSK OZ	2
**221	000-P00420	M4X20 MSCR PAN PAS	5
**222	012-P00325	N4X1" S/TAP PAN PAS	4
**223	020-B00316-0B	M3X16 SKT BH BLK	2
**224	029-B00412	M4X12 SKT BH PAS	6
**225	060-S00400	M4 WSHR SPR PAS	6
**306	SND-60007UK	WH BASEBOC TO COCKPIT	1
**307	SND-60008UK	WH FAN & LED	1
**308	SND-60009UK	WH TICKET VEND & MICROSW	1
**311	SND-60012UK	WH BUTTONS	1
**312	SND-60018UK	WH SPEAKERS B	1
**314	SND-60020UK	WH LED CNTRL A2	1
**315	SND-60027UK	WH LED CNTRL B2	1
**317	600-7500-180UK	SER CABLE 9P M/F 22-0012-04	1
**320	600-9050-44K	WH EARTH 50CM M4/M4 K	1
**321	600-9150-44K	WH EARTH 150CM M4/M4 K	1
**323	600-7141-100UK	CABLE JVS TYPE A-B 100cm	1
**324	600-7009-2500UK	ASSY RGB CA D-SUB 15	1
**325	600-7155-0180UK	CA AUDIO 3.5MM JACK M/M 1.8M 628-7196	1
**326	600-9025-44K	WH EARTH 250MM M4/M4	1
**327	600-9050-45K	WH EARTH 500MM M4/M5	1

⑤ ASSY AC UNIT (SND-1080UK)

(D-1/1)

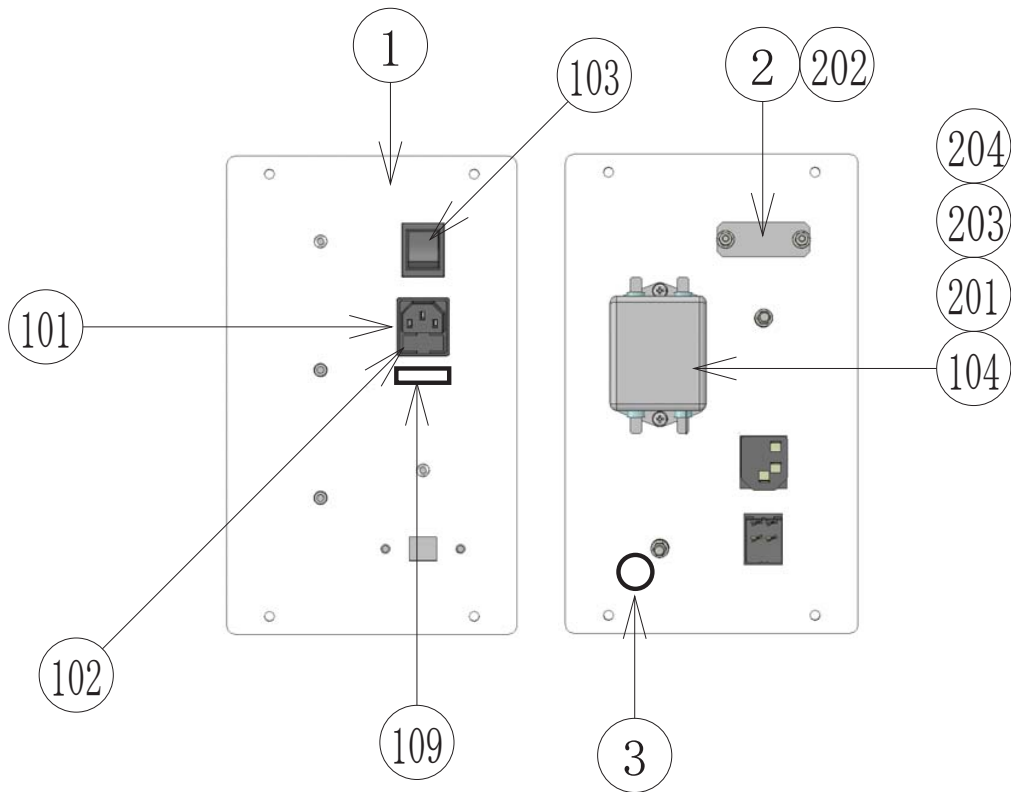

ITEM	PART NUMBER	DESCRIPTION	QTY
***1	DV-1081UK	PLATE AC	1
***2	ST-0403UK	PLATE AC CAP	1
***3	LB1096	STICKER PROTECTIVE EARTH	1
***101	EP1302	EUROSOCKET FUSED 10A 250VAC	1
***102	514-5078-3150	FUSE 3.15 T 20MM C RS537-1509	2
***103	SW1109	SWITCH ROCKER 250V AC	1
***104	EP1419	FILTER SCHAFFNER 2030-16-06	1
***108	310-5029-D508	HEAT SHRINK SLEEVING 50.8DIA	4
***109	LB1126-3150-250	FUSE LABEL 3.15A 250V	1
			2
***201	029-B00412	M4X12 SKT BH PAS	2
***202	050-F00400	M4 NUT FLG SER PAS	4
***203	060-F00400	M4 WSHR FORM A FLT PAS	2
***204	060-S00400	M4 WSHR SPR PAS	2
***301	SND-60001UK	WH AC IN	1



## ⑥ ASSY DPAD CONTROLLER (SND-1100UK)

(D-1/1)

18 PARTS LIST

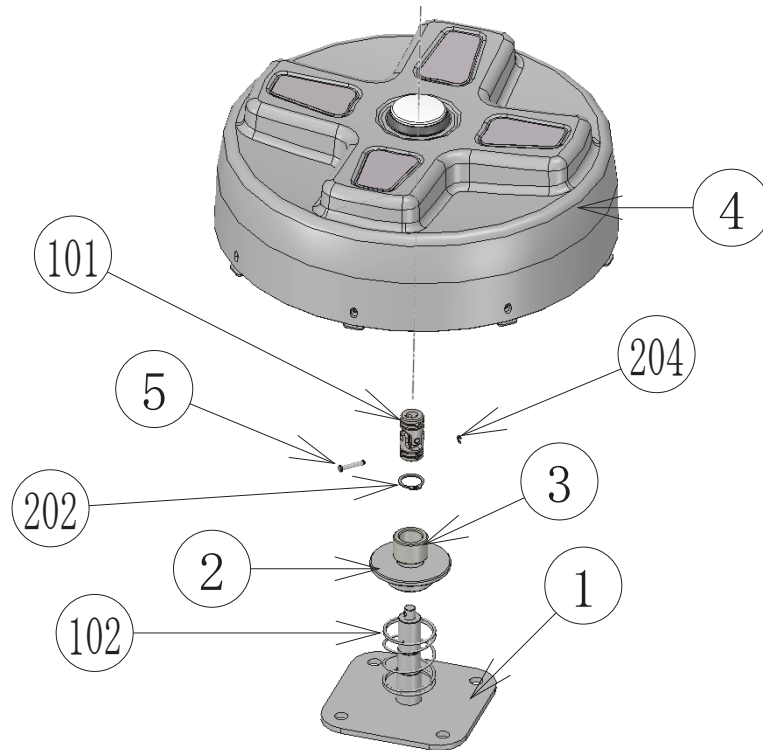

ITEM NO	PART NUMBER	DESCRIPTION	QTY
***1	SND-1101UK	BASE CONTROLLER	1
***2	SND-1102UK	BASE SPRING RETAINER	1
***3	SND-1103UK	BASE SPACER	1
***4	SND-1150XUK	SUB ASSY DPAD CONTROLLER	1
***5	SND-1159UK	PIN UNIV JOINT RETAIN	1
***101	111-0001-91UK	UNIV JOINT 10X20X42	1
***102	125-0004UK	SPRING COMP SND DPAD	1
***201	065-C02000	CIRCLIP 20MM	1
***202	065-C04200	CIRCLIP 42MM	1
***203	045-K00438-OZ	4X38 SPIRAL PIN OZ	1
***204	065-E00400	E RING 4MM	1
***301	SND-60014UK	WH SERIAL CROSS KEY A	2
***302	SND-60016UK	WH SERIAL CROSS KEY B	1
***303	SND-60015UK	WH CROSS KEY LED	1

⑦ ASSY SUB ASSY DPAD CONTROLLER (SND-1150UK)

(D-1/1)

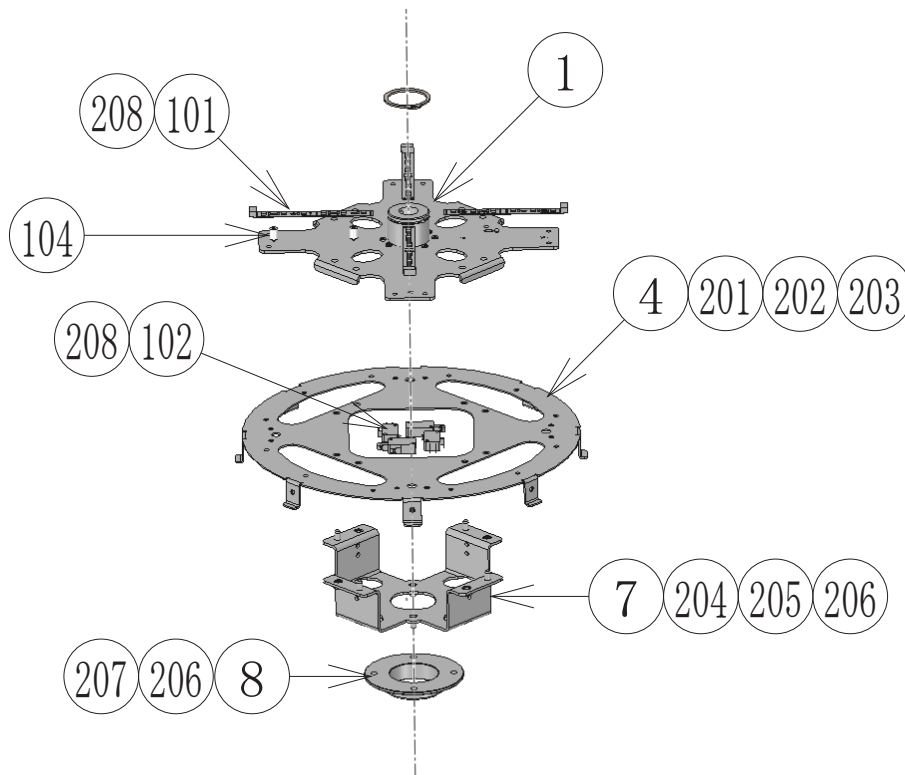

ITEM NO	PART NUMBER	DESCRIPTION	QTY
****1	SND-1151XUK	BASE CONT UPPER	1
****4	SND-1154XUK	PLATE DISC	1
****7	SND-1157XUK	PLATE CAM	1
****8	SND-1158UK	BASE CAM LOWER	1
****101	601-13101-003	CROSS KEY LED ELE-F01770	4
****102	EP1464	SW MICRO RS 159-4411	4
****104	280-L00811-OS	STANDOFF 7.94OD 3.56ID 11.11L	8
****201	029-B00412	M4X12 SKT BH PAS	8
****202	060-S00400	M4 WSHR SPR PAS	8
****203	068-441614	M4 WSHR 16OD FLT PAS	8
****204	029-B00612	M6X12 SKT BH PAS	4
****205	060-S00600	M6 WSHR SPR PAS	4
****206	068-652016	M6 WSHR 20OD FLT PAS	8
****207	050-U00600	M6 NUT NYLOK PAS	4
****208	020-B00316-0B	M3X16 SKT BH BLK	16
****301	SND-60014UK	WH SERIAL CROSS KEY A	2
****302	SND-60015UK	WH CROSS KEY LED	1
****303	SND-60016UK	WH SERIAL CROSS KEY B	1

⑧ ASSY DPAD COVER (SND-1170UK)

(D-1/1)

18 PARTS LIST

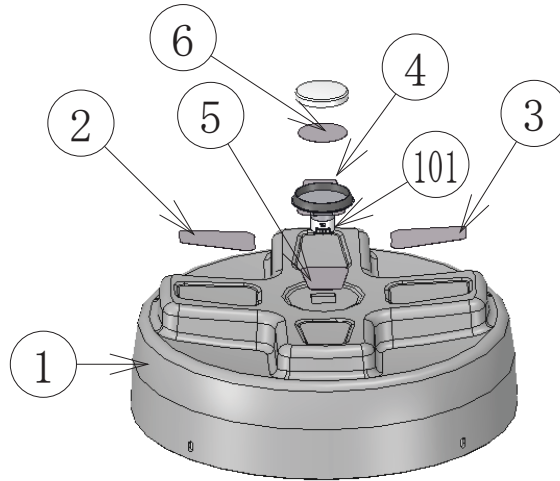

ITEM NO	PART NUMBER	DESCRIPTION	QTY
***1	SND-1160UK	COVER DPAD	1
***2	SND-1161-01UK	DECAL DPAD L	1
***3	SND-1161-02UK	DECAL DPAD R	1
***4	SND-1161-03UK	DECAL DPAD UP	1
***5	SND-1161-04UK	DECAL DPAD DOWN	1
***6	SND-1305UK	BUTTON INFILL/INSERT	1
***101	509-0011-01	GPB890 LR HALO BLK/BLU LED U2	1

⑨ ASSY MONITOR 55" (SND-1250UK)

(D-1/1)

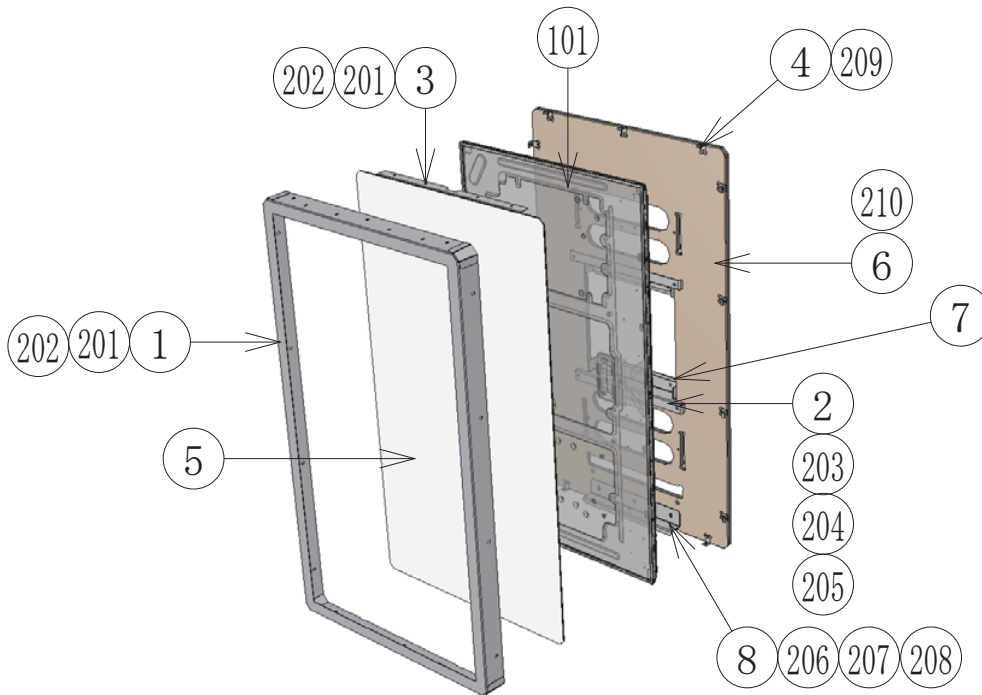

ITEM NO	PART NUMBER	DESCRIPTION	QTY
***1	RND-0198	SND MASK MON 55 METAL	1
***2	SND-1202UK	BRKT MONITOR MTG	2
***3	SND-1253UK	BRKT GLASS RETAIN HORIZ 55	2
***4	SND-1204UK	BRKT MON MASK SUPP	13
***5	SND-1255UK	GLASS MONITOR 55	1
***6	SND-1256UK	PANEL MONITOR BACK 55	1
***7	SND-1257UK	SPACER MTG 55	2
***8	SND-1009UK	BRKT SUPP LWR MON 42	1
***101	200-6055-03-AUO	55" LED AUO P550HVN02.2	1
***102	OS1230	FOAM STRIP 2MM X 10MM	1.1
***201	029-B00412-0B	M4X12 SKT BH BLK	21
***202	068-441614-0B	M4 WSHR 16OD FLT BLK	21
***203	029-B00812-0B	M8X12 SKT BH BLK	4
***204	060-S00800-0B	M8 WSHR SPR BLK	4
***205	068-852216-0B	M8 WSHR 22OD FLT BLK	4
***206	029-B00616-0B	M6X16 SKT BH BLK	3
***207	060-S00600-0B	M6 WSHR SPR BLK	3
***208	068-652016-0B	M6 WSHR 20OD FLT BLK	3
***209	012-P03512-FB	N6x1/2" S/TAP FLG BLK	13
***210	012-F03532	N6X1 1/4" S/TAP CSK PAS	4

⑩ ASSY CTRL PAN (SND-1300UK)

(D-1/1)

18

PARTS LIST

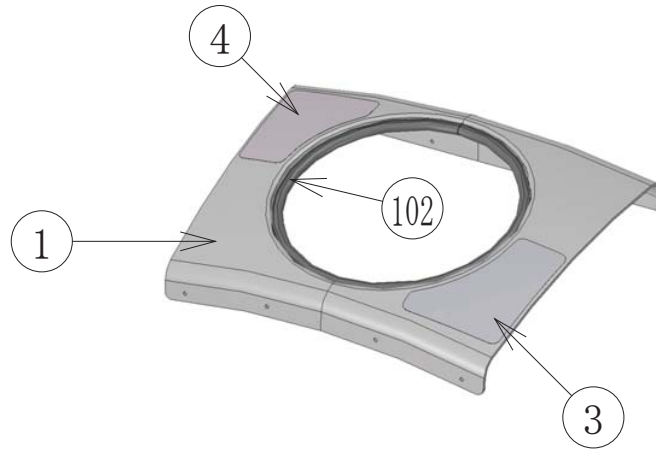

ITEM NO	PART NUMBER	DESCRIPTION	QTY
***1	SND-1301UK	COVER CTRL PNL	1
***3	SND-1303UK	STICKER START SURROUND	1
***4	SND-1304UK	STICKER PLAY INST	1
***102	OS1253	EDGING RUBBER BODY SIDE SEAL	1.2
****108	310-5029-D508	HEAT SHRINK SLEEVING 50.8DIA	4
****109	LB1126-5-250	FUSE LABEL 5A 250V	1
****201	000-P00308-W	M3X8 MSCR PAN W/FS PAS	2
****202	050-F00400	M4 NUT FLG SER PAS	4
****301	TFF-60001UK	WH AC IN	1
****302	600-9020-44K	WH EARTH 200MM M4/M4	1

⑪ ASSY FAN (SND-1340UK)

(D-1/1)

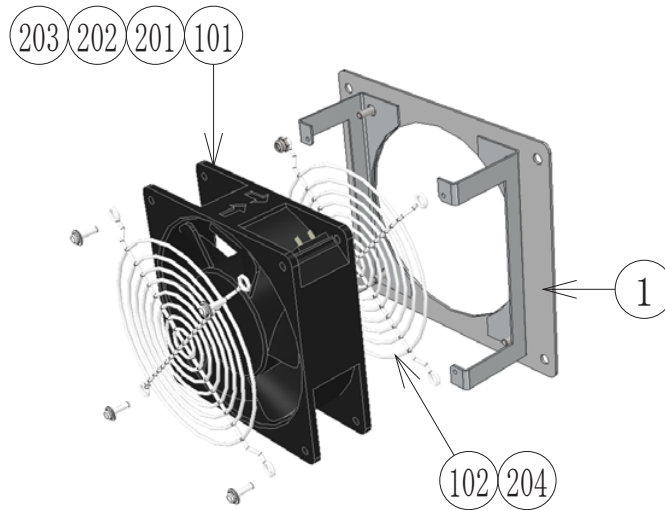

ITEM NO	PART NUMBER	DESCRIPTION	QTY
***1	SND-1341UK	BRKT FAN MTG	1
***101	260-0012-01UK	FAN DC 12V AXIAL	1
***102	FN1012	FAN GUARD METAL 120MM (FG-12)	2
***201	020-B00316-0B	M3X16 SKT BH BLK	4
***202	060-S00300-0B	M3 WSHR SPR BLK	4
***203	060-F00300-0B	M3 WSHR FORM A FLT BLK	4
***204	050-U00400	M4 NUT NYLOK PAS	4
****202	050-F00400	M4 NUT FLG SER PAS	4
****301	TFF-60001UK	WH AC IN	1
****302	600-9020-44K	WH EARTH 200MM M4/M4	1

⑫ ASSY HALF HOOP L (SND-1400UK)

(D-1/1)

18 PARTS LIST

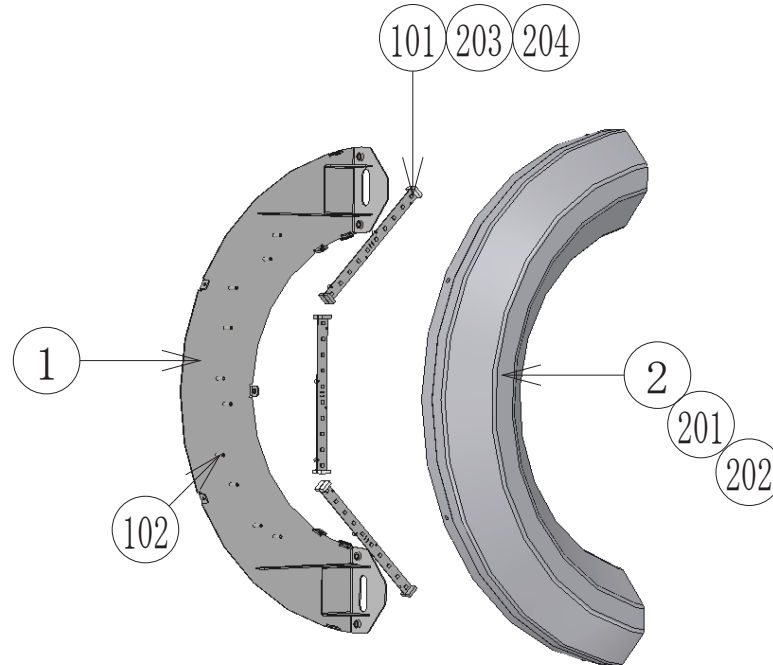

ITEM NO	PART NUMBER	DESCRIPTION	QTY
***1	SND-1401XUK	BRKT BASE HALF LOOP	1
***2	SND-1402-02UK	COVER SIDE RING (HALF)	1
***101	601-13101-001	HALF RING LED ELE-F01750	3
***102	280-L00605-OS	STANDOFF 6.35OD 3.56ID 4.76L	10
***201	029-B00412	M4X12 SKT BH PAS	7
***202	068-441614	M4 WSHR 16OD FLT PAS	7
***203	020-B00316-0B	M3X16 SKT BH BLK	10
***204	068-330808-PN	M3 WSHR 8OD FLT NYLON	10
***301	SND-60013UK	WH SERIAL RGB XY	2
***302	SND-60021UK	WH LED HALF HOOP L	1
***303	SND-60022UK	WH LED HALF HOOP EXTENSION A	1

⑬ ASSY HALF HOOP R (SND-1450UK)

(D-1/1)

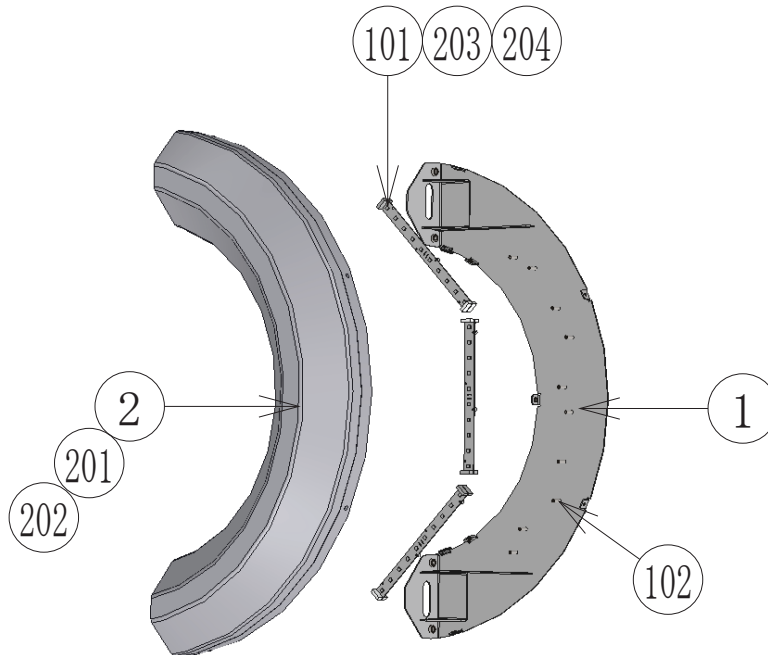

ITEM NO	PART NUMBER	DESCRIPTION	QTY
***1	SND-1401XUK	BRKT BASE HALF LOOP	1
***2	SND-1402-02UK	COVER SIDE RING (HALF)	1
***101	601-13101-001	HALF RING LED ELE-F01750	3
***102	280-L00605-OS	STANDOFF 6.35OD 3.56ID 4.76L	10
***201	029-B00412	M4X12 SKT BH PAS	7
***202	068-441614	M4 WSHR 16OD FLT PAS	7
***203	020-B00316-0B	M3X16 SKT BH BLK	10
***204	068-330808-PN	M3 WSHR 8OD FLT NYLON	10
***301	SND-60013UK	WH SERIAL RGB XY	2
***302	SND-60030UK	WH LED HALF HOOP R	1
***303	SND-60022UK	WH LED HALF HOOP EXTENSION A	1



⑭ ASSY FULL HOOP L (SND-1500UK)

(D-1/2)

18 PARTS LIST

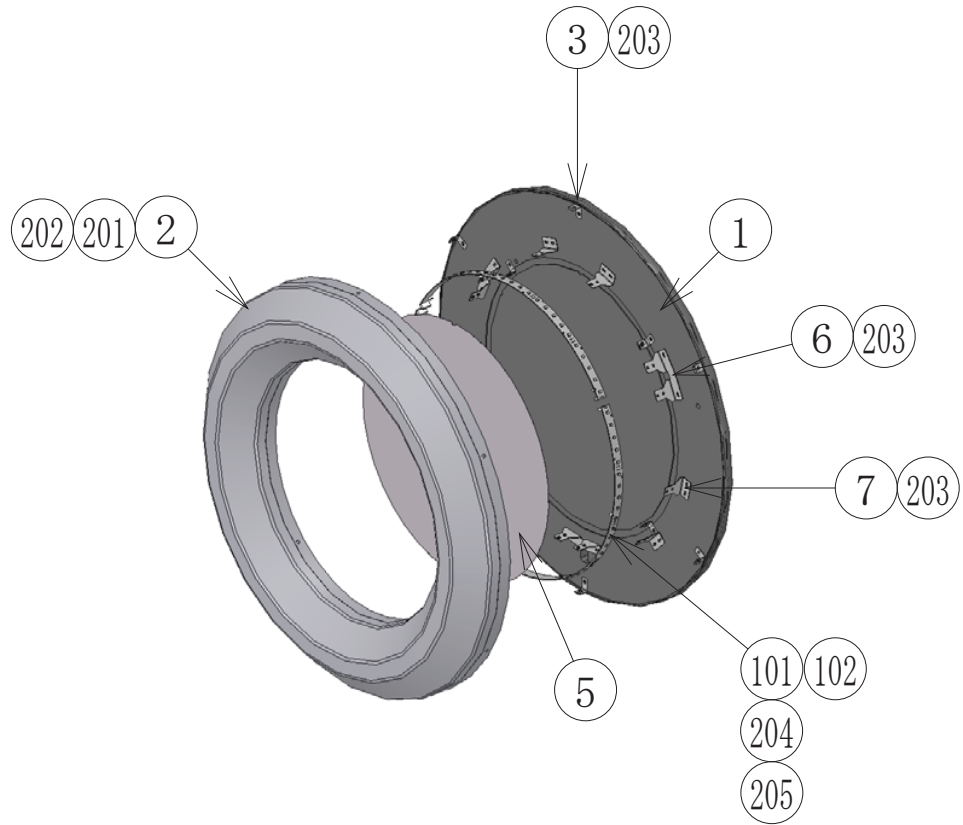

ITEM NO	PART NUMBER	DESCRIPTION	QTY
***1	SND-1501XUK	DISC L	1
***2	SND-1402-01UK	COVER SIDE RING	1
***3	SND-1512XUK	BRKT LED MTG FULL HOOP	10
***5	SND-1505UK	INFILL FULL HOOP L	1
***6	SND-1510XUK	BRKT LED MTG FULL HOOP DUAL	3
***7	SND-1511XUK	BRKT LED MTG FULL HOOP	6
***101	601-13101-002	RING LED ELE-F01760	3
***102	280-L00605-OS	STANDOFF 6.35OD 3.56ID 4.76L	12
***201	029-B00412	M4X12 SKT BH PAS	9
***202	068-441614	M4 WSHR 16OD FLT PAS	9
***203	012-P03512-FB	N6x1/2" S/TAP FLG BLK	28
***204	020-B00316-0B	M3X16 SKT BH BLK	12
***205	068-330808-PN	M3 WSHR 8OD FLT NYLON	12
***301	SND-60013UK	WH SERIAL RGB XY	2
***302	SND-60024UK	WH LED FULL HOOP L	1
*****304	600-9020-44K	WH EARTH 20CM M4M4	1

⑮ ASSY FULL HOOP L (SND-1550UK)

(D-1/2)

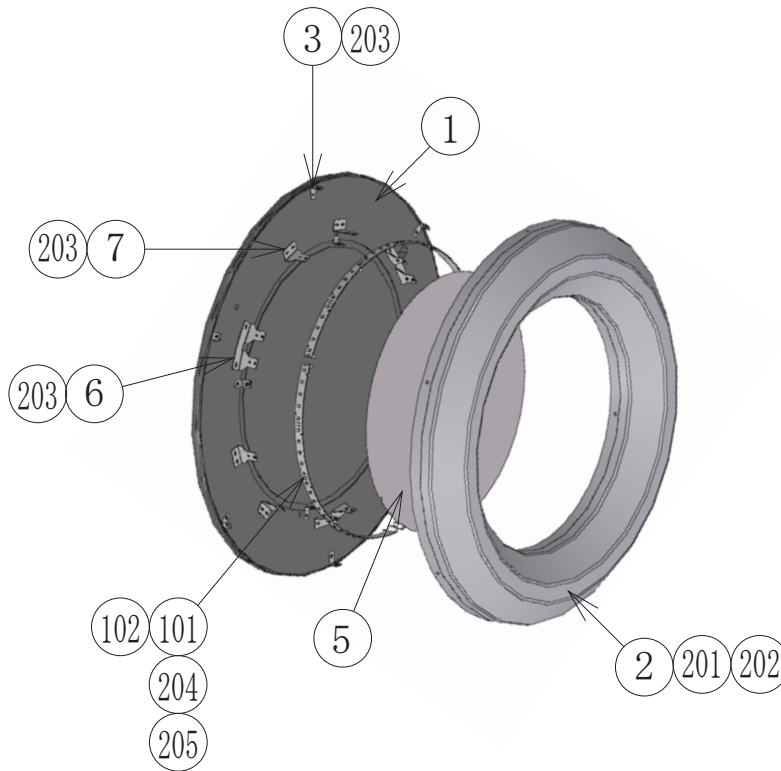

ITEM NO	PART NUMBER	DESCRIPTION	QTY
***1	SND-1551XUK	DISC R	1
***2	SND-1402-01UK	COVER SIDE RING	1
***3	SND-1512XUK	BRKT LED MTG FULL HOOP	10
***5	SND-1506UK	INFILL FULL HOOP R	1
***6	SND-1510XUK	BRKT LED MTG FULL HOOP DUAL	3
***7	SND-1511XUK	BRKT LED MTG FULL HOOP	6
***101	601-13101-002	RING LED ELE-F01760	3
***102	280-L00605-OS	STANDOFF 6.35OD 3.56ID 4.76L	12
***201	029-B00412	M4X12 SKT BH PAS	9
***202	068-441614	M4 WSHR 16OD FLT PAS	9
***203	012-P03512-FB	N6x1/2" S/TAP FLG BLK	28
***204	020-B00316-0B	M3X16 SKT BH BLK	12
***205	068-330808-PN	M3 WSHR 8OD FLT NYLON	12
***301	SND-60013UK	WH SERIAL RGB XY	2
***302	SND-60025UK	WH LED FULL HOOP R	1

①6 ASSY MAIN ELEC (SND-4000UK)

(D-1/2)

ITEM NO	PART NUMBER	DESCRIPTION	QTY
***1	SND-4001UK	WOODEN BASE MAIN	1
***2	SND-4002UK	PLATE PSU MTG	1
***101	837-14572	I/O CONTROL BD 3 FOR JVS COM	1
***102	400-100-012-02	PSU 12VDC 100W MW SP-100-12	1
***103	400-100-05-01	PSU 5V 100W MW LPS-100-05	1
***104	400-150-012-02	PSU 12VDC 150W MW SP-150-12	1
***105	601-13101-004	LED CONTROL BD ELE-F01780	1
***106	838-14551-02UK	AC DISTRIBUTION BD	1
***107	838-8001UK	AMP 2.2 VISATON	1
***108	CFB-4003-01UK	EARTH PLATE	1
***109	280-A01264-WX	ROUTER TWIST D12 SO6.4 WOOD X	8
***110	280-A02064-WX	ROUTER TWIST D20 SO6.4 WOOD X	8
***111	OS1011	PCB FEET	8
***201	029-B00412	M4X12 SKT BH PAS	12
***202	060-S00400	M4 WSHR SPR PAS	12
***203	068-441614	M4 WSHR 16OD FLT PAS	4
***204	012-P00325	N4X1" S/TAP PAN PAS	8
***205	012-P00312	N4X1/2" S/TAP PAN PAS	8
***206	012-P03512-FB	N6x1/2" S/TAP FLG BLK	4
***301	SND-60002UK	WH AC DISTRIBUTION	1
***302	SND-60003UK	WH DC DISTRIBUTION	1
***303	SND-60004UK	WH MONITOR PSU	1
***304	SND-60005UK	WH I/O	1
***305	SND-60017UK	WH SPEAKERS A	1
***305	SND-60026UK	WH LED CNTRL B1	1
***306	SND-60028UK	WH LED CNTRL A1	1
***306	EP1467	USB A - USB MINI 2M	1

①⑥ ASSY MAIN ELEC (SND-4000UK)

(D-2/2)

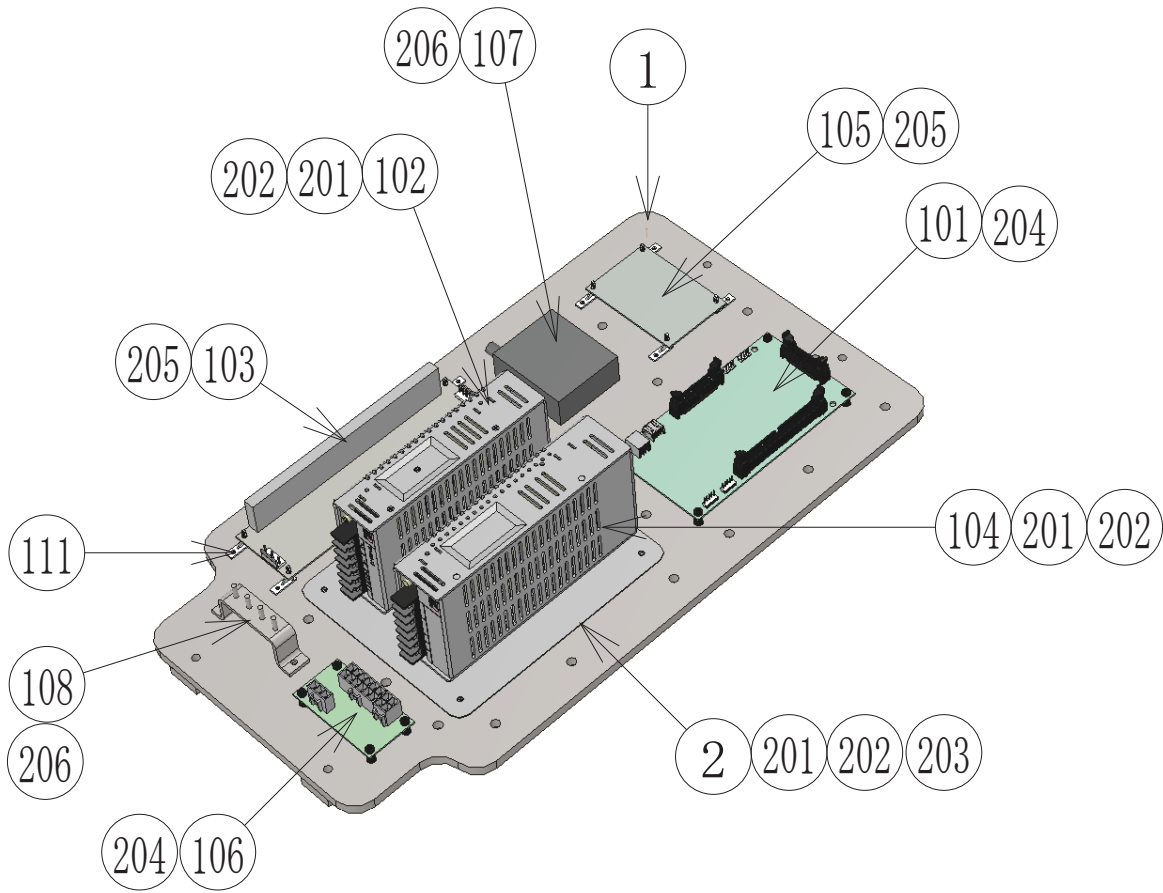

⑰ ASSY LED MONITOR ELEC (SND-4100UK)

(D-1/1)

18 PARTS LIST

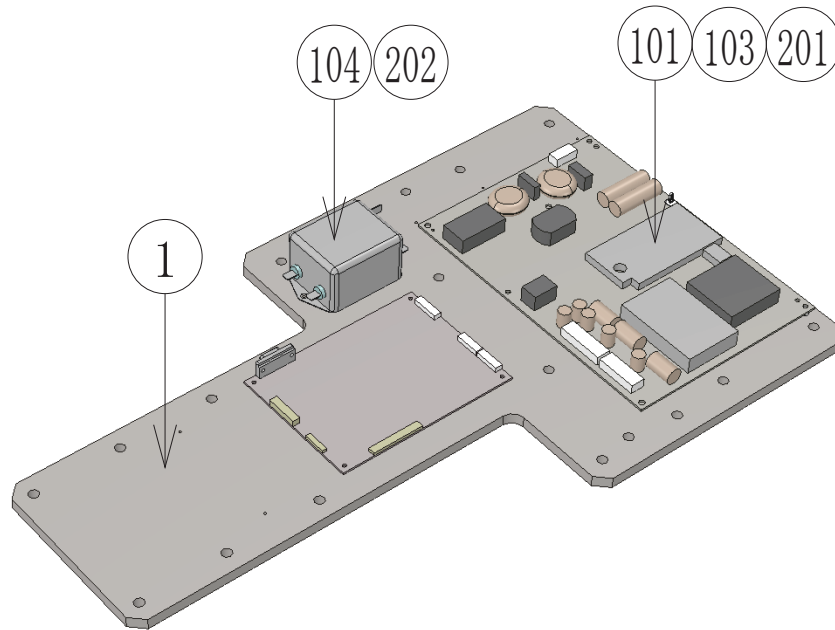

ITEM NO	PART NUMBER	DESCRIPTION	QTY
***1	SND-4101UK	PLATE PRISMA BD DMODUL MOUNT	1
***2	440-DS0010UK	LABEL DANGER HI VOLT GEN	1
***101	400-160-51224	PSU 42" LED DPS-160AP-2A-PD02	1
***102	280-A01264-WX	ROUTER TWIST D12 SO6.4 WOOD X	12
***103	280-L00709-OS	STANDOFF 70D 4ID 9L	10
***104	EP1419	FILTER SCHAFFNER 2030-16-06	1
***201	012-P00325	N4X1" S/TAP PAN PAS	10
***202	012-P03512-FB	N6x1/2" S/TAP FLG BLK	2

## 19 COLOUR CODE TABLE

### WARNING

The DC power wire color for this product is different from previous SEGA titles. Working from the previous wire colors will create a high risk of fire.

The color codes for the wires used in the diagrams in the following chapter are as follows.

- A PINK
- B SKY BLUE
- C BROWN
- D PURPLE
- E LIGHT GREEN

Wires other than those of any of the above 5 single colors will be displayed by 2 alphanumeric characters.

- 1 RED
- 2 BLUE
- 3 YELLOW
- 4 GREEN
- 5 WHITE
- 7 ORANGE
- 8 BLACK
- 9 GRAY

If the right-hand side numeral of the code is 0, then the wire will be of a single color shown by the left-hand side numeral (see the above).

Note 1: If the right-hand side numeral is not 0, that particular wire has a spiral color code. The left-hand side character shows the base color and the right-hand side one, the spiral color.

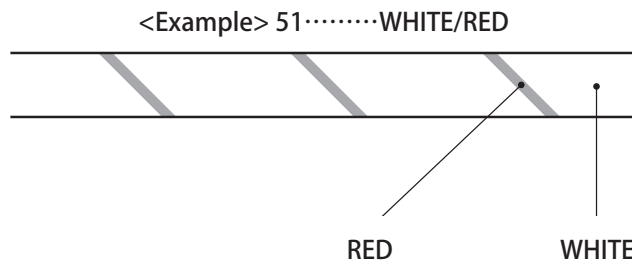

Note 2: The character following the wire color code indicates the size of the wire.

- U: AWG16
- K: AWG18
- L: AWG20
- None: AWG22

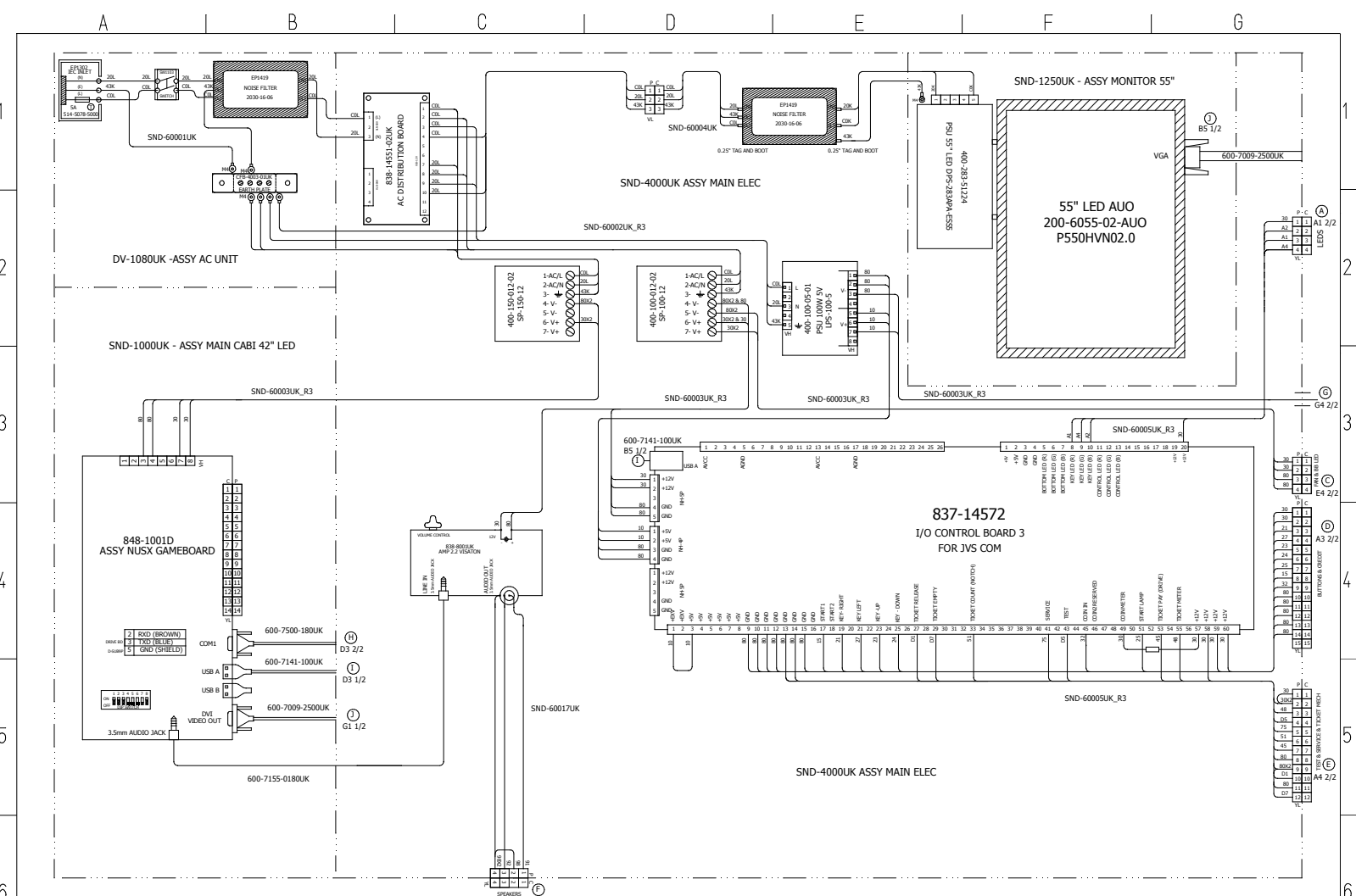

8	BLACK	43	EARTH WIRE
7	ORANGE	44	AVSB UL 8P2
6	WHITE	45	AWSD UL 3P2
5	GREEN	46	AWSD UL 3P5
4	BROWN	47	AWSB UL 3P5
3	YELLOW	48	AWSD UL 3P5
2	BLUE	49	AWSD UL 3P5
1	RED	50	AWSD UL 3P5

1	BLACK	51	AVSB UL 8P2
2	ORANGE	52	AWSD UL 3P2
3	WHITE	53	AWSD UL 3P5
4	GREEN	54	AWSD UL 3P5
5	BROWN	55	AWSD UL 3P5
6	YELLOW	56	AWSD UL 3P5
7	BLUE	57	AWSD UL 3P5
8	RED	58	AWSD UL 3P5

SD	SEGA AMUSEMENTS EUROPE LTD	THE SYMBOLS IN THIS DIAGRAM ARE THE SYMBOLS IN IEC
SD	SONIC DASH EXTREME	GENERAL SEE
30/4/2015		PAGE 1 OF 2 A2

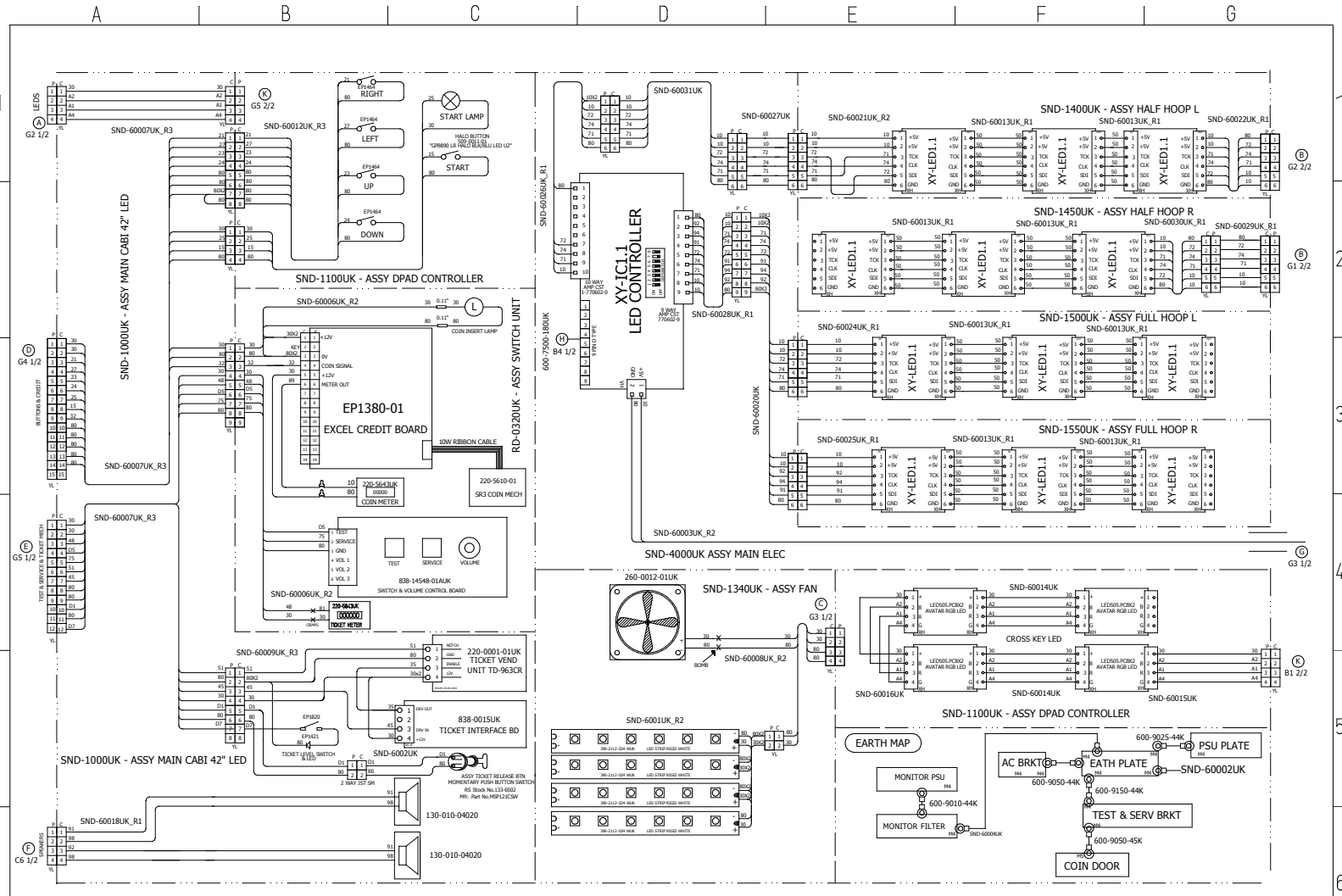

<b>8 BLACK</b> <b>7 ORANGE</b> <b>6 WHITE</b> <b>4 GREEN</b> <b>3 YELLOW</b> <b>2 BLUE</b> <b>1 RED</b>		<b>13 LIGHT GREEN</b> <b>12 PINK</b> <b>11 SKY BLUE</b> <b>10 BROWN</b> <b>9 GREY</b>		<b>14 EARTH WIRE</b> <b>15 AW500 - U1 2P2</b> <b>16 AW500 - U1 3P2</b> <b>17 AW500 - U1 3P5</b> <b>18 AW500 - U1 3P5</b> <b>19 AW500 - U1 3P5</b> <b>20 AW500 - U1 3P5</b>		<b>SND-0000UK</b> <b>SD</b> <b>30/4/2015</b>		<b>SEGA AMUSEMENTS EUROPE LTD</b> <b>SONIC DASH EXTREME</b>		<b>16 PIN BLENDED PAPER</b> <b>4981 SE</b> <b>PAGE 2 OF 2 A2</b>	
ALTERATION		PART NUMBER		DRAWN		DESCRIPTION					